

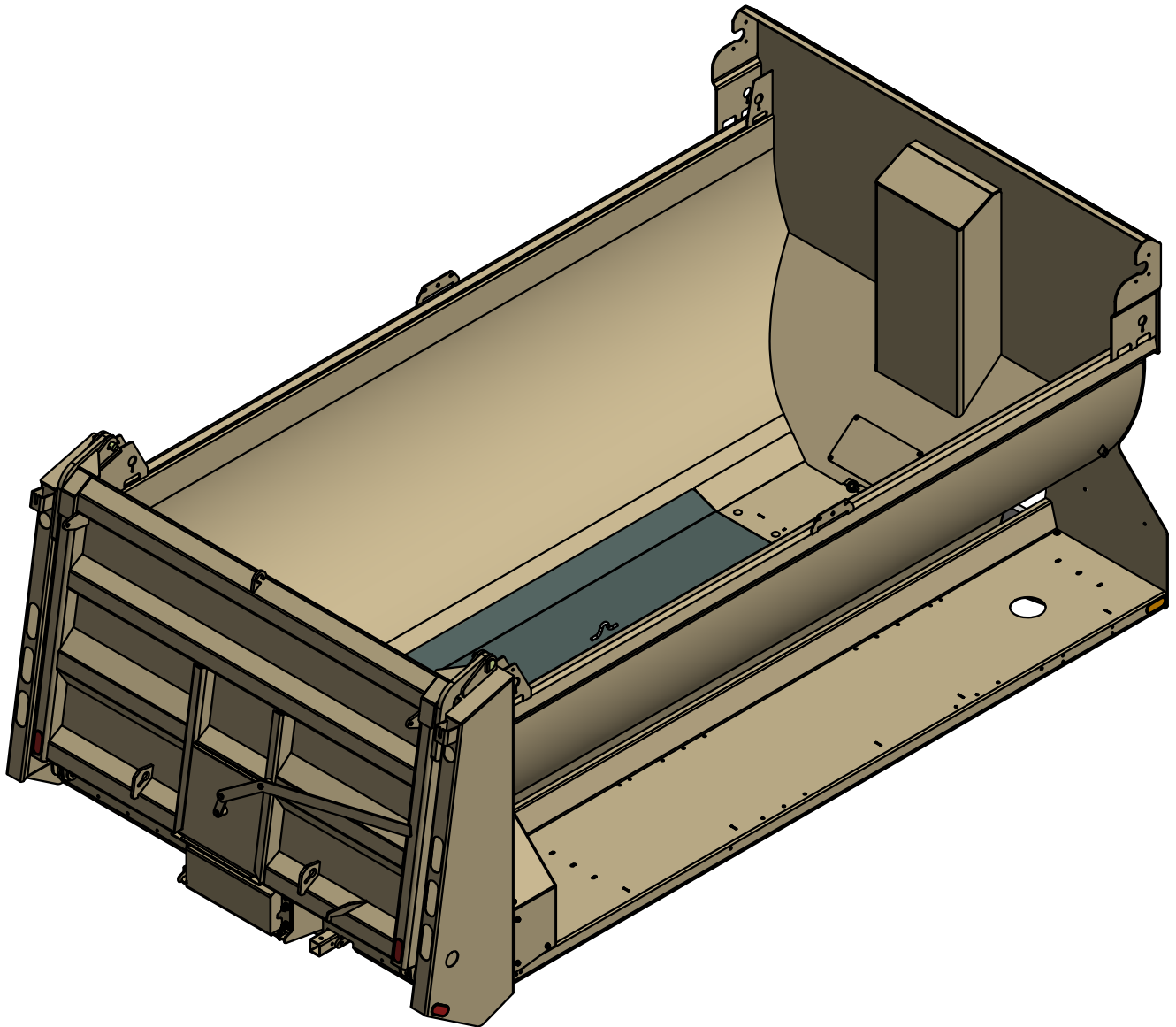

Owners Manual Proline Dual Auger (PLDA)





Proline Combination Spreader Model Codes

All Pro-Line Combination Spreaders have an associated model code, which identifies the style, type and length of body. The model codes used to describe a Pro-Line Combination Spreader can be broken down as follows:

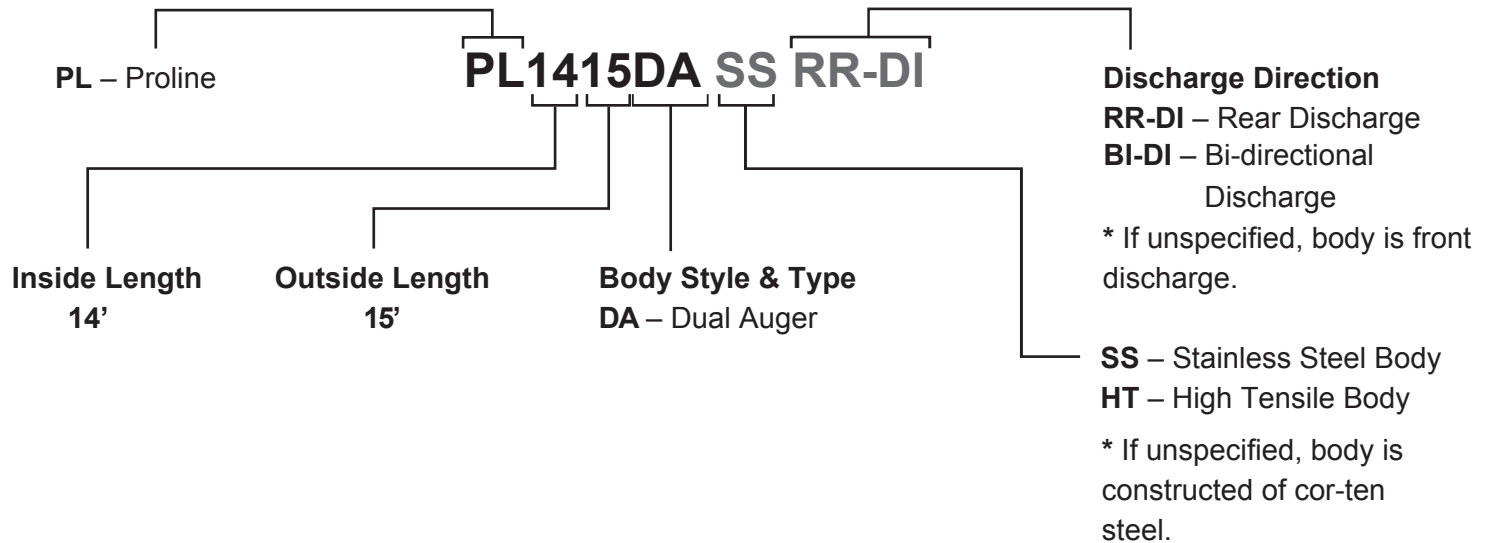

PLDA Combination Spreader Capacities

The Proline Combination Spreader is designed to handle a wide range sand and salt for snow and ice control.

Approximate Capacities of Proline Dual Auger Combination Spreaders:

Body Length	Water Level Capacity	Capacity with 10' Sideboards	Side Height	Inside Overall Length	Outside Overall Length
PL1415DA	10.9 cu. yds.	14.0 cu. yds.	43"	172"	178"



Body Prop Safety Precautions



DANGER: When servicing the area under the raised body, ensure the following:

- Truck is on solid, level ground.
- The dump body is completely emptied of all material (salt, gravel, asphalt, etc...)
- Raised body is supported by the safety prop pins in the upright position.
- Hoist control lever is in the neutral position.
- PTO is disengaged and the unit is in lockout.

Never attempt service under the raised dump body without the above items satisfied, failure to do so may result in serious injury or death.

Raising Dump Body & Supporting With Prop Pins

To raise and secure dump body, follow these steps:

1. Raise dump body to 20°-30° (degrees), and place hoist valve in neutral (hold) position.
2. Remove body prop pins from storage location and insert into holes located on each side in front of dump hinge.
3. Before lowering dump hinge reinstall hairpin locking body pins in place.
4. Lower body slowly until profiled hinge block contacts the prop pins.

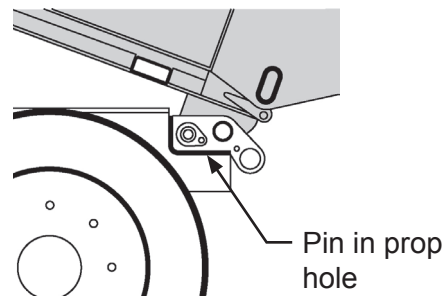
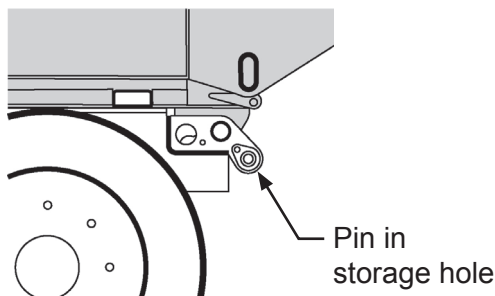

To remove Prop Pins:

1. Raise the dump body sufficiently to take load of prop pins, and place hoist control valve in neutral (hold) position.
2. Remove pins from prop holes on both sides and return to storage location provided. **Before lowering body be sure that area below box is completely clear.**
3. Lower body to rest on chassis frame rails.

Alternate Blocking Method:

1. Railway tie or piece of wood approximately 6"x6"x5' to lay across frame rails just ahead of dump hinge and extended approximately 1 ft. each side of frame.
 2. Place two, 4" X 4" blocks approximately 5' long between tandem tires and block securely against body underside.
-



0820112-DUAL AUGER DECAL KIT PROLINE SAFETY ANSI Z535.3

SAFETY PRECAUTIONS, DECALS AND MESSAGES

Before operating your Pro-Line Dual Auger Combination Spreader, familiarize yourself with the following safety precautions. The following illustrations show the Viking-Cives Group caution and warning decals. The following illustrations will show the different decals, their content, and where to find them on the equipment.

Always ensure that the decals are clean, visible and legible. If any decals become worn, damaged or lost, contact your Viking-Cives dealer immediately to order replacements.

SAFETY INSTRUCTIONS

1. Do NOT use this equipment before reading and understanding the operator's manual.
2. Do NOT lift dump body when truck is moving.
3. The opening control of the rear gate must be locked when the truck is moving.
4. The truck must be in a stable position before starting to lift the dump body.
5. Do NOT tip on recently excavated ground or in filling ground if the soil is not properly compacted.
6. When lifting or dumping, the user must at all times be in control of the operation.
7. The rear gate must be released before starting to lift the dump body.
8. Nobody should stand in the cylinder's operation area when in action.
9. Before dumping, make sure nobody stands in the area.
10. Before starting the spreading mechanism, make sure nobody stands near the spreader.
11. Never stand inside the dump body when the conveyor is in operation.
12. Before starting the spreader, make sure that the outflowing gate is open.
13. When the dump body is not in operation, it must at all times lay on the truck frame.
14. When truck is not in use, remove keys from ignition.
15. When using the dump body as a spreader, use screens for loading.

0820102

0820102

SAFETY INSTRUCTIONS



COMPLETELY UNLOAD BODY PRIOR TO USING PROP TO USE PIN TYPE BODY PROP:

1. Raise body 30 to 40 degrees. Place hoist control valve in neutral (Hold) position.
2. Remove body prop pins from storage location and insert into holes located on each side in front of dump hinge.
3. Before lowering dump hinge re-install hairpin locking body prop pin in place.
4. Lower body slowly until profiled hinge block contacts the prop pins.

TO REMOVE PIN TYPE BODY PROP:

1. Raise body sufficiently to take load off of prop pins. Place hoist control valve in neutral (Hold) position.
2. Remove pins from both sides and return to storage location. Before lowering body be sure that area below box is clear.

0820103

0820112-DUAL AUGER: DECAL KIT PROLINE SAFETY ANSI Z535.3



0820093

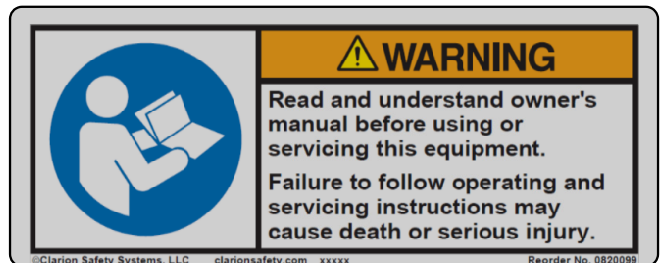

0820099



0820096



0820101



0820098



0820108



0820097



0820112-DUAL AUGER: DECAL KIT PROLINE SAFETY ANSI Z535.3

ITEM ID	ITEM NO	DESCRIPTION	QTY REQ
1	0820093	DECAL DANGER WING	2
2	0820096	DECAL CAUTION SCREENS	1
3	0820097	DECAL DANGER FALLING BODY	2
4	0820098	DECAL DANGER ENTER BODY	1
5	0820099	DECAL WARNING READ MANUAL	1
6	0820101	DECAL CAUTION BEHIND TRUCK	2
7	0820102	DECAL SAFETY INFO PROLINE	2
8	0820103	DECAL SAFETY INSTRUCT PROPS	2
9	0820108	DECAL WARNING PINCH POINT	2

NOTE:

The "READ MANUAL" 0820099 decal is to be located in the cab.

NOTE:

0820112 decal kit comes with more decals than shown in the above bill of materials. Only use those listed above for PLDA assemblies.

NOTE:

Three of decal 0820111 "WARNING AUGER, MOVING PARTS" are also required. These decals are not part of this kit but are shown on this drawing for reference.



BOX 1120, NORPARK DRIVE, MOUNT FOREST, ONT. N0G 2L0 (519)323-4433 PH (519)323-4608 FX

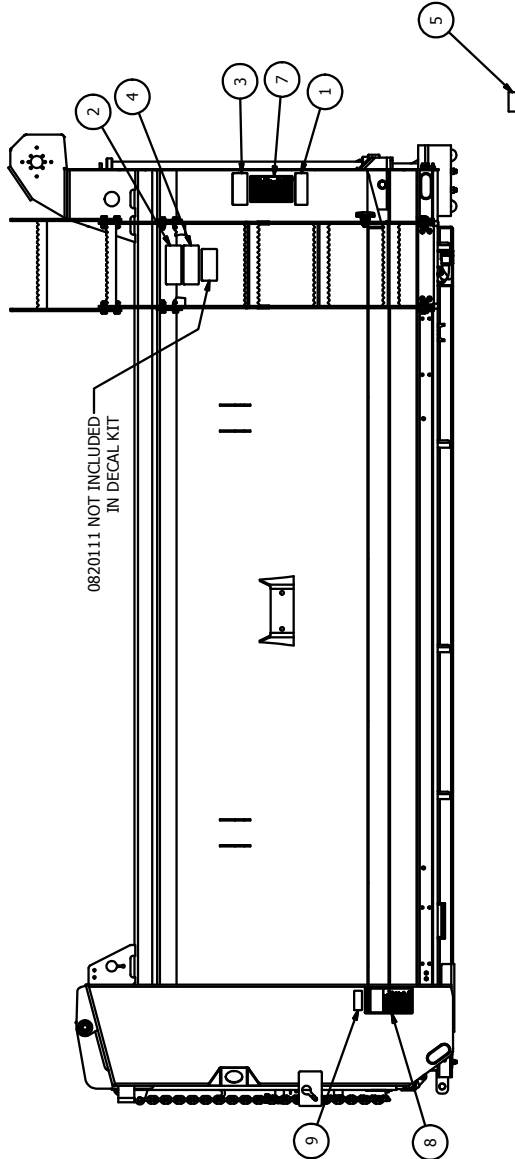

DECAL 0820099 IS TO BE LOCATED IN THE CAB.

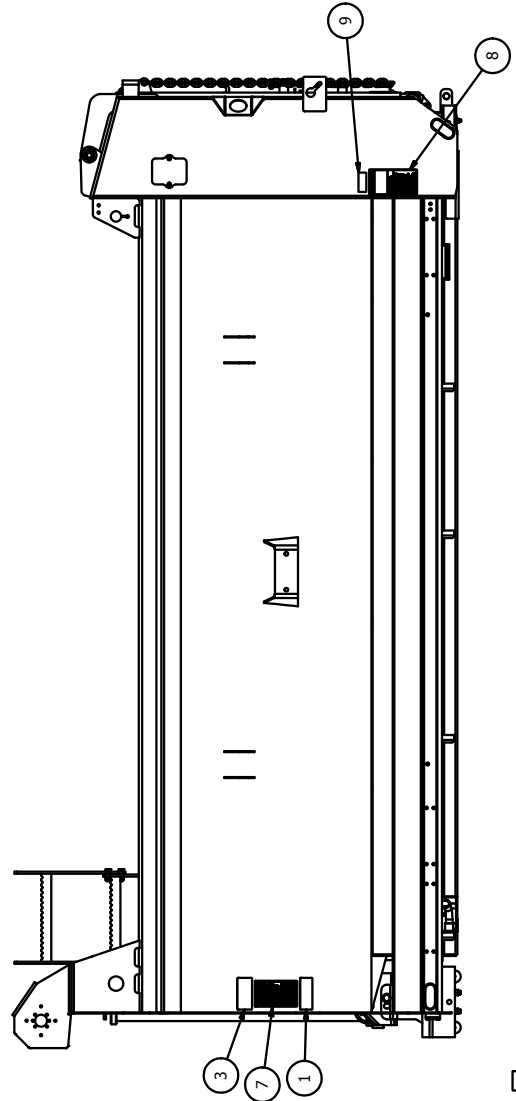

0820111 NOT INCLUDED IN DECAL KIT

0820111 NOT INCLUDED IN DECAL KIT

EQUIPMENT MAY NOT BE EXACTLY AS SHOWN. SOME COMPONENTS MAY BE OPTIONAL. TO MAINTAIN OUR ON-GOING PRODUCT DEVELOPMENT AND IMPROVEMENT PROGRAM, VIKING-GIVES LTD. RESERVES THE RIGHT TO CHANGE EQUIPMENT & SPECIFICATION WITHOUT NOTICE.



BOX 1120, NORPARK DRIVE, MOUNT FOREST, ONT. N0G 2L0 (519)323-4433 PH (519)323-4608 FX

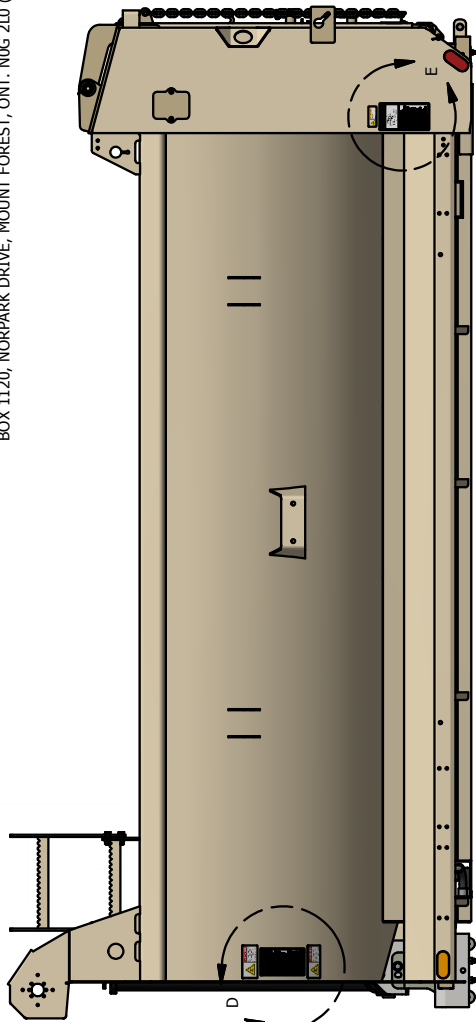

DRIVER SIDE VIEW

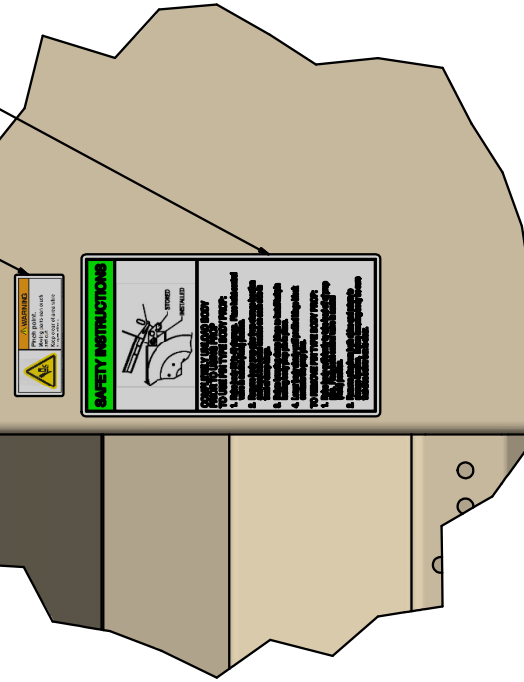

DETAIL E
SCALE 3 : 8

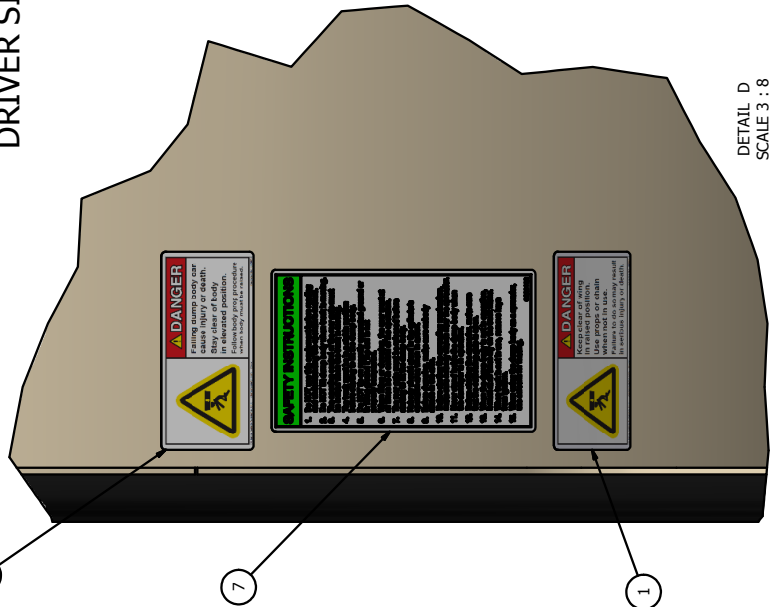

DETAIL D
SCALE 3 : 8

EQUIPMENT MAY NOT BE EXACTLY AS SHOWN. SOME COMPONENTS MAY BE OPTIONAL. TO MAINTAIN OUR ON-GOING PRODUCT DEVELOPMENT AND IMPROVEMENT PROGRAM, VIKING-GIVES LTD. RESERVES THE RIGHT TO CHANGE EQUIPMENT & SPECIFICATION WITHOUT NOTICE.



BOX 1120, NORPARK DRIVE, MOUNT FOREST, ONT. N0G 2L0 (519)323-4433 PH (519)323-4608 FX

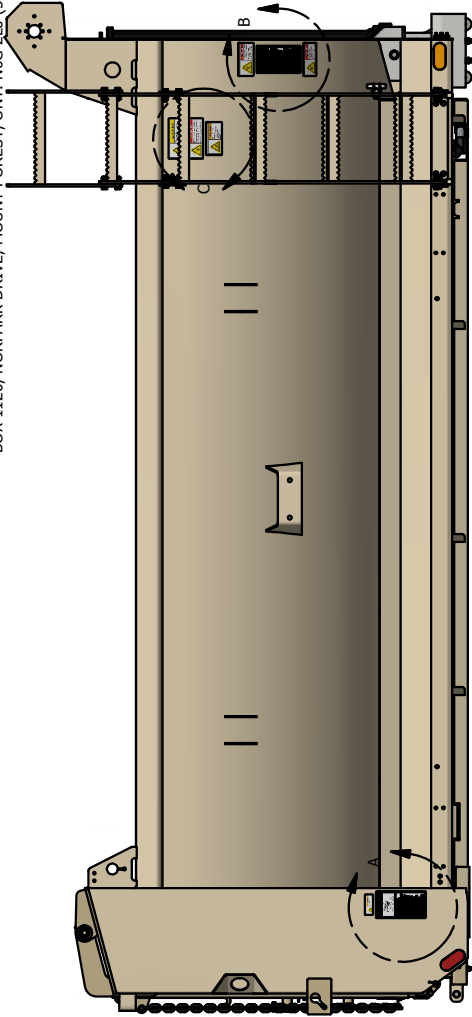

PASSENGER SIDE VIEW

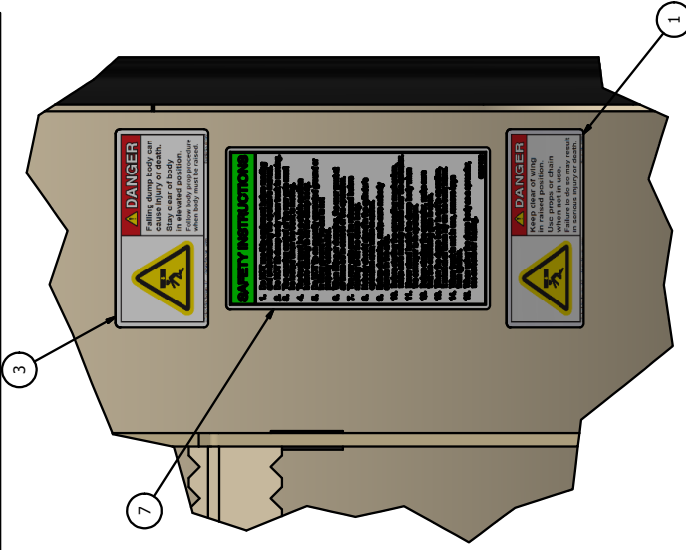

DETAIL B
SCALE 3 : 8

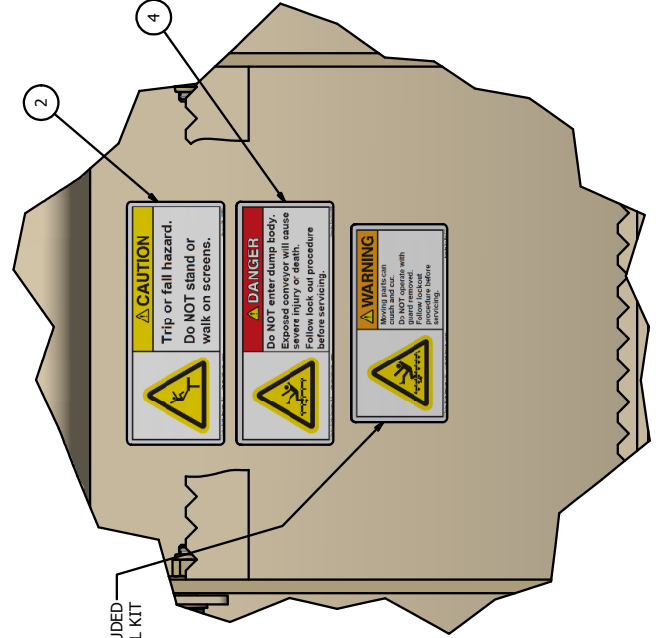

DETAIL C
SCALE 3 : 8

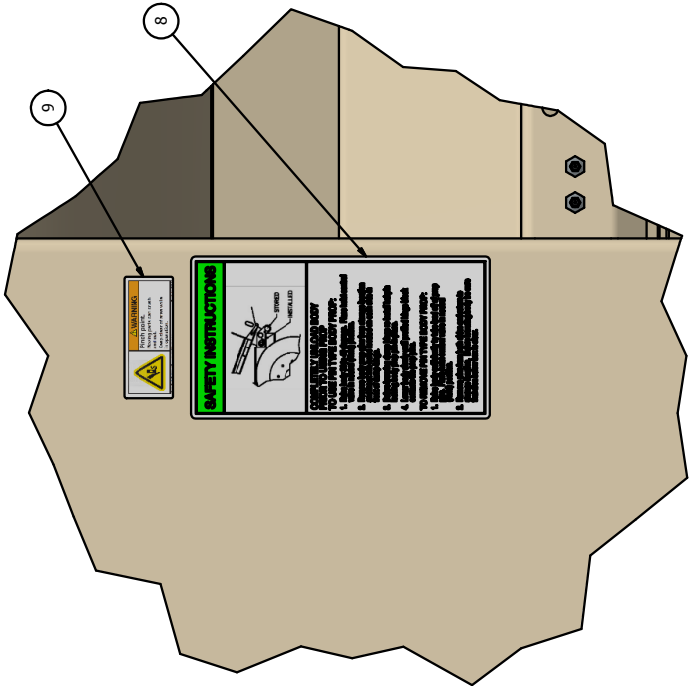

DETAIL A
SCALE 3 : 8

0820111 NOT INCLUDED
IN DECAL KIT

EQUIPMENT MAY NOT BE EXACTLY AS SHOWN. SOME COMPONENTS MAY BE OPTIONAL. TO MAINTAIN OUR ON-GOING PRODUCT DEVELOPMENT AND IMPROVEMENT PROGRAM, VIKING-GIVES LTD. RESERVES THE RIGHT TO CHANGE EQUIPMENT & SPECIFICATION WITHOUT NOTICE.

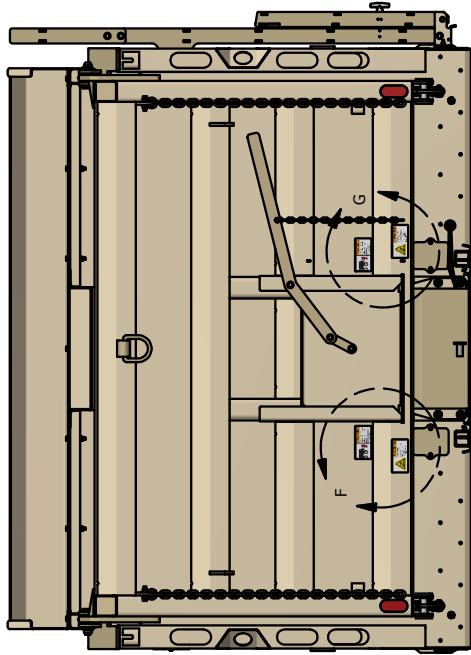

REAR VIEW

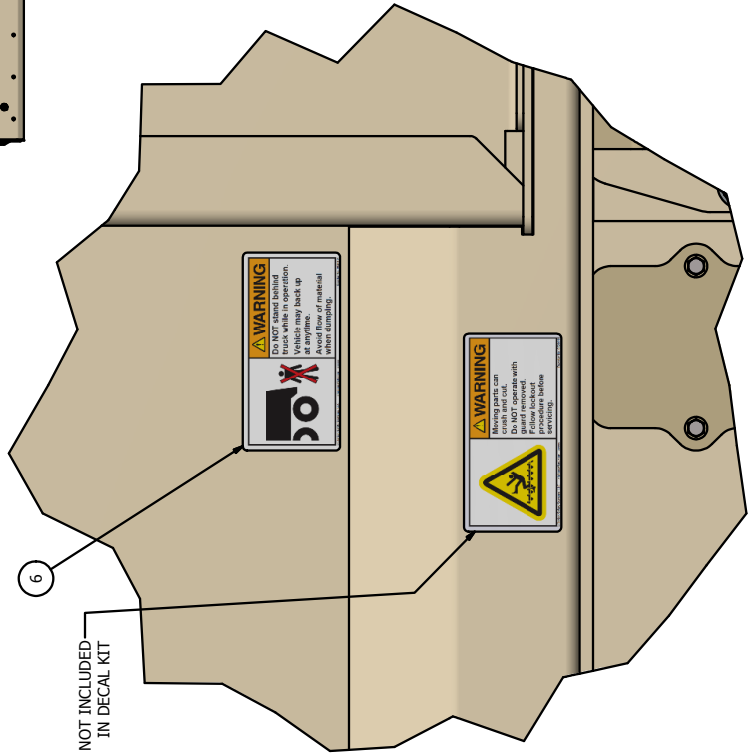

DETAIL F
SCALE 3 : 8

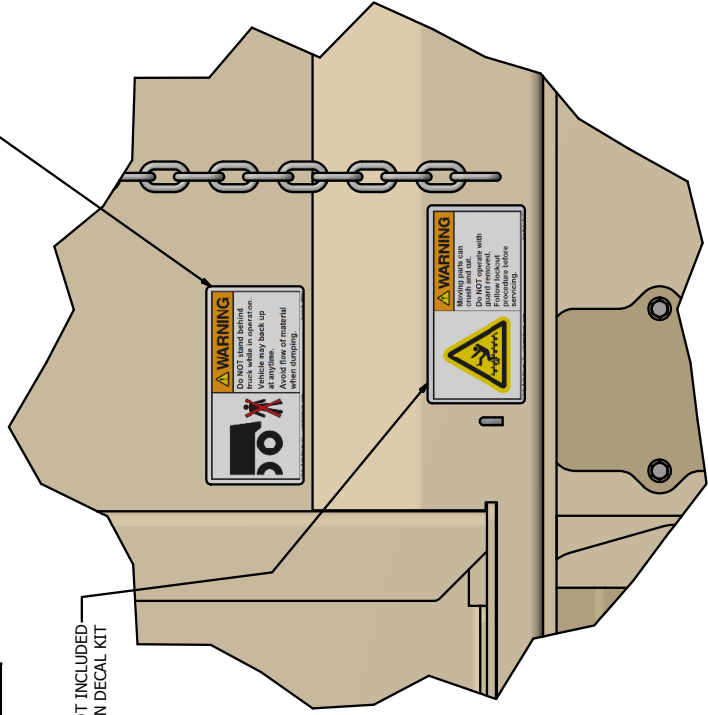

DETAIL G
SCALE 3 : 8

EQUIPMENT MAY NOT BE EXACTLY AS SHOWN. SOME COMPONENTS MAY BE OPTIONAL. TO MAINTAIN OUR ON-GOING PRODUCT DEVELOPMENT AND IMPROVEMENT PROGRAM, VIKING-GIVES LTD. RESERVES THE RIGHT TO CHANGE EQUIPMENT & SPECIFICATION WITHOUT NOTICE.



Maintenance

Preventive Maintenance Inspection & Lubrication

Proper maintenance of your Proline Combination Spreader is essential for a long service life, as well as ensuring that the equipment performs optimally. The maintenance procedures outlined will aid your Proline Combination Spreader in performance and longevity.



CAUTION: Before any adjustment, service or maintenance is performed on the spreader, ensure to understand and follow all safety rules:

- Keep all shields and guards in place when operating this equipment.
 - Adjust and lubricate spreader, only when the power source is off and locked out.
 - The drive shafts, conveyor, and spinner assemblies transmit great amounts of power, and are hazardous when in operation. All maintenance, inspections, or operator adjustments must be made with all source power off.
 - When the spreader becomes clogged, shut off the power source and lock it out before attempting to clear the blockage.
 - Keep hands, feet and clothing away from moving parts and pinch points.
-



Maintenance Schedule

 Adjust

 Check/Inspect



 Replace



 Lubricate

Initial Maintenance

During the first weeks of use, operating forces may cause hardware to loosen as the new machine is subjected to exceptional forces. Additionally, Hydraulic oils break down quickly and become contaminated as debris from manufacturing processes. Initial maintenance is paramount to the efficient operation and service life of the equipment.

First 20 Hours of Operation

  Inspect for loose bolts, pins, conveyor chains, and tighten/adjust as required.

  Inspect hydraulic fluid for contamination and level. Add fluid or change as needed.

 Thoroughly lube all mechanical parts – bearings, hoist mounting, chains, and adjusters.

 Inspect auger gearbox oil for contamination and level. Oil sample should be taken from the oil level hole, not the drain hole.

 Change hydraulic system filter(s).

First 50 & 100 Hours of Operation



 Change auger gearbox gear oil.



NOTE: Never mix mineral and synthetic oils in gearbox. Viking-Cives Group recommends using an antifoaming gear oil grade SAE80/90EP.





Regular Maintenance

Daily Maintenance

  Check the fluid level in the hydraulic oil reservoir. If the sight indicates low oil level, add the appropriate amount of the specified hydraulic fluid.



  Visually Inspect all fasteners. Tighten or replace, if necessary.



  Visually inspect all hydraulic connections and hoses for cracks and/or leaks. Rupturing hoses may produce a high-pressure stream of hot hydraulic oil.



 At the beginning of each shift visually inspect all caution and warning decals. All decals should be complete and legible. If decals are not legible, clean them. If cleaning the decals does not make them legible, install new decals.

 Check all auger beds for excessive wear or damage.

Clean unit - wash all areas clean of salt and road dirt to prevent corrosion.

  Visually inspect all battery terminals and electrical connections, wires, switches, etc. for signs of corrosion, wear, loose and/or broken connections, etc.

  At the beginning of each shift review all lighting accessories to ensure proper working conditions, immediately replace any broken or non-functioning bulbs and/or lenses.

  Inspect tailgate locking mechanism. Adjust as required.

Tailgate Linkage Adjustment:

The tailgate linkage is meant to hold the tailgate tight against the back of the box. If through time the linkage loosens, readjust by following these steps:

1. Remove the clevis pin from tailgate claw
2. Screw out the adjustable yoke on the spring brake chamber, to take up any slack.
3. Replace clevis and pin to the tailgate claw.

WARNING: The spring brake chambers used in the design of the Proline tailgate locks are self-contained sealed units. They contain compression springs under pre-load pressure.

These units are tamper-resistant and completely sealed with a unique precision weld, joining the steel center section and the steel housing.

Viking-Cives Ltd. does not recommend servicing these units, as mishandling could result in severe injury.



Weekly Maintenance

As part of an on-going preventive maintenance program, your Pro-Line Combination Spreader should be regularly lubricated.

The following list indicates both the location and number of lubrication points for a standard Dual Auger body. Additional lubrication points may exist on your particular unit. Please consult Viking-Cives and/or nearest authorized dealer for specific lubrication diagrams.

 Grease all required components at the beginning of each season, then once a week.

- Hoist Cylinder:

- a. Hoist base pivot blocks (4)
- b. Bottom mounting pin (2)

- Main Body Assembly:



- a. Main auger rear end bearings (2)
- c. Dump hinge pin (2)
- d. Tailgate hinge pin (2)

Monthly Maintenance



 Check bolt tightness at valve, cab controls, body guides, and drive shaft bearings.

 Check structural welds at dump hinge, hoist frame and body for cracks due to fatigue or overload.

 Inspect augers for possible wear; bolts for tightness.

  Inspect hydraulic fluid color for possible contamination. If oil appears thick or dirty, drain and replace fluid/filter(s).

NOTE: Excessive foaming can be an indication of air and/or moisture presence in the hydraulic system.

  Check for oil leaks in all hydraulic fittings and hoses. Retighten and/or replace fittings and hoses as required.





Mid-Season Maintenance

 Replace hydraulic system return oil filter (10-micron absolute) element.

 Replace oil(s) and all filters if excessive dirt or metallic particles are evident.

 Inspect oil(s) for contaminants in conveyor gearbox and hydraulic reservoir.

End of Season Maintenance

  Remove spinner(s) inspect bearings, couple hoses on spinner and on truck.

 Thoroughly wash down auger beds, and lubricate each with a non-water soluble lubricant.

 Inspect auger, covers, bearings, and shafts for wear or damage.

 Change auger gearbox oil, and hydraulic fluids and filters.

Recommended Filters

Viking-Cives recommends that all hydraulic filter elements are a minimum 10-micron absolute. Additionally the use of electronic spreader control systems requires greater filtration and therefore should be equipped with an in-line high-pressure filter and element. Viking- Cives Group recommends changing filter elements more frequently at three (3) month intervals.



09701253-DA : LUBRICATION POINTS PLDA

ITEM ID	LOCATION	ASSEMBLY DESCRIPTION	QTY/UNIT
1	UPPER TRUNNION (REMOTE)	1/8 NPT	2
2	CYLINDER SEALS (REMOTE)	1/8 NPT	2
3	LOWER TRUNNION	1/8 NPT	2
4	REAR AUGER END BEARINGS (REMOTE)	GREASE FITTING / BEARING	2
5	TAILGATE HINGE PINS	1/4 - 28 UNF	2
6	DUMP HINGE PIN	1/8 NPT	2

EQUIPMENT MAY NOT BE EXACTLY AS SHOWN. SOME COMPONENTS MAY BE OPTIONAL.
TO MAINTAIN OUR ON-GOING PRODUCT DEVELOPMENT AND IMPROVEMENT PROGRAM, VIKING-CIVES LTD. RESERVES THE RIGHT TO CHANGE EQUIPMENT & SPECIFICATION WITHOUT NOTICE.



BOX 1120, NORPARK DRIVE, MOUNT FOREST, ONT. N0G 2L0 (519)323-4433 PH (519)323-4608 FX

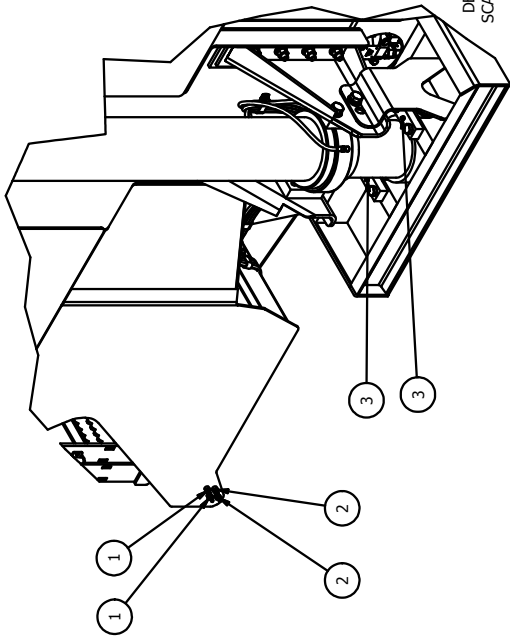

DETAIL A
SCALE 1 / 10

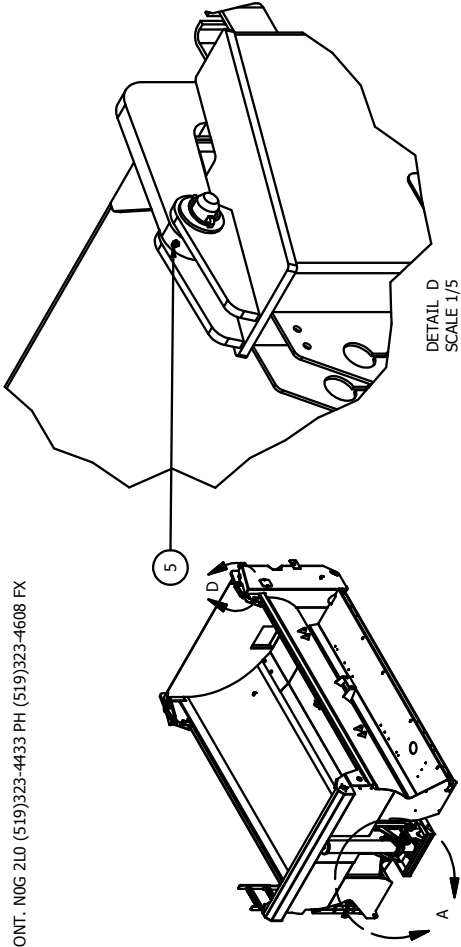

DETAIL D
SCALE 1/5

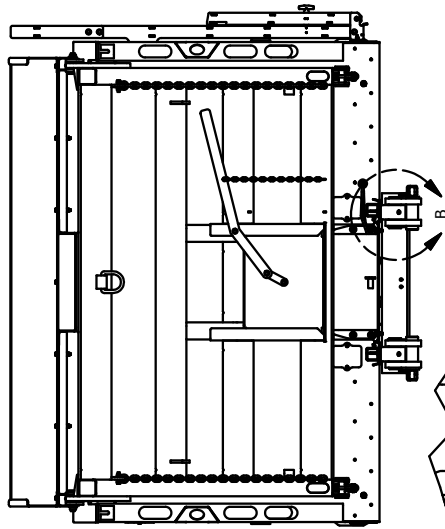

DETAIL B
SCALE 1 / 5

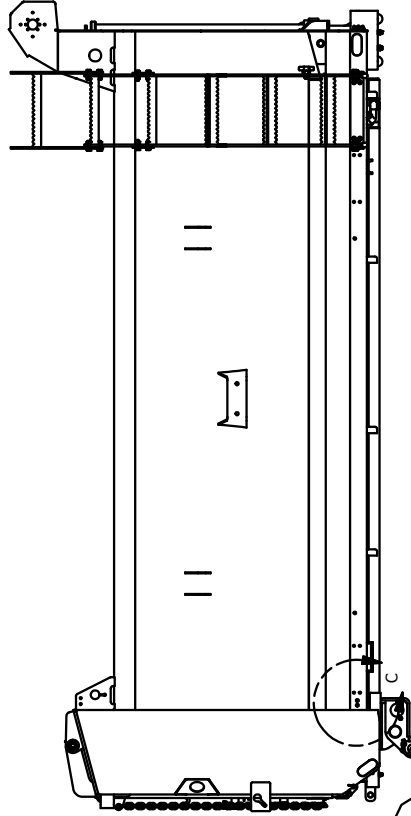

DETAIL C
SCALE 1 / 5

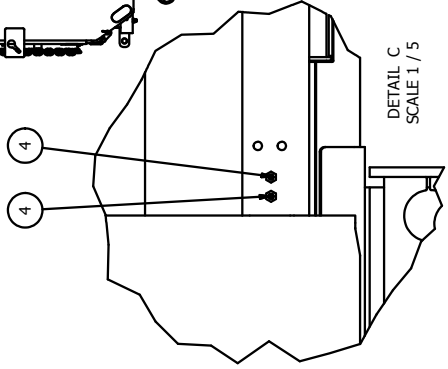

TO MAINTAIN OUR ON-GOING PRODUCT DEVELOPMENT AND IMPROVEMENT PROGRAM, VIKING GIVES LTD. RESERVES THE RIGHT TO CHANGE EQUIPMENT & SPECIFICATION WITHOUT NOTICE.



Operating Instructions



CAUTION: Before operating any equipment, be sure to read and fully understand all caution and safety warnings. Familiarize yourself and others with all caution/warning labels and their locations. Make sure all labels are complete and legible. Replace any labels that have become unreadable and/or missing. Replacement labels can be purchased directly from Viking-Cives Group, and/or nearest authorized dealer.

IMPORTANT: Before putting any equipment into use, check for any worn, damaged or loose components, if necessary repair or replace. Listen for any unusual sounds, if necessary repair and/or replace worn or damaged parts. Check all lighting systems to ensure proper function and replace any broken lights before operating on public roads.

The operator should familiarize themselves with all equipment prior to operation. The in cab controls are placed at a comfortable reach of the operator and are clearly marked as to the equipment/function they control.

Dump Body Operation.

1. With the engine running, pull the dump raise lever in the cab back toward the rear of the unit.
2. If dumping a load, the air operated tailgate release valve should be pulled to the open position to operate tailgate release mechanism. This must be done before raising the body.
3. To lower body, push the dump lever forward.
4. To stop and hold dump body in any position while raising or lowering the unit, release the lever and it will automatically center itself in a neutral position.

Sander Operation

An automated or electronic spreader control system enables the operator to discharge the payload manually, or have it metered automatically. The system synchronizes the application rate, based on predetermined values, with the vehicle ground speed. A control console within the cab allows the operator to control any of the units spreading functions. For detailed operating instructions, refer to the "Owner's Manual" supplied with automated control unit.

Cold Weather Operation

All equipment is designed to operate with hydraulic oil minimally warm. During cold weather conditions, it is recommended that the truck be run at idle with the pump engaged and circulating the oil through the system before operating equipment. Install chassis mounted hydraulic components (i.e. hydraulic pump/PTO, main valve bank, etc).

Dumping Operation



DANGER: Dumping operations can be extremely dangerous. Always ensure that you follow the proper safety precautions and exercise common sense when dumping loads. Failure to do so may result in damage to the equipment, severe injury, or death.



DANGER: DO NOT dump on uneven, unstable ground.



WARNING: Prior to dumping, ensure that the tailgate claws have been released.

ALWAYS ensure that the vehicle is parked on a stable and level surface.

NEVER attempt to raise dump body if the surface grade exceeds 6 degrees. Raising a load on an uneven surface can cause the vehicle to tip.

NEVER attempt to raise a load on excessively muddy or moist surfaces.

NEVER transport the vehicle with a disproportionately rearward load. Uneven loads that collect at the tailgate can alter the vehicle's weight distribution and affect the handling and stability of the vehicle when in motion.



DANGER: Always stay clear of overhead structures and power lines.

ALWAYS ensure that there are no power lines or overhead structures that can interfere with the dump body while it is being raised.

NEVER raise dump body under power lines. Fallen power lines can cause severe injury or death to operators and bystanders, and can leave large areas without power for long periods of time.

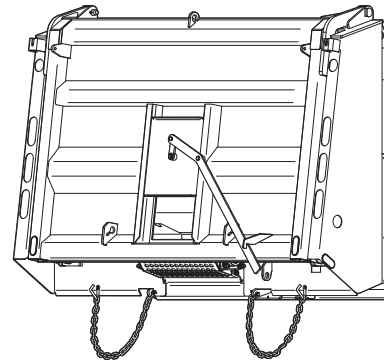

NEVER attempt to dump through the coal door by raising the dump body as it can cause the load to shift to the rear of the truck. It is only to be used to discharge material out the rear when the body is down using the conveyor.



WARNING: Clear all bystanders to a safe distance when dumping

ALWAYS ensure that the area is clear of bystanders. Clear discharge area (rear and the sides of the vehicle) of all bystanders.

ALWAYS ensure that all bystanders are visible to the operator while dumping.

IT IS THE OPERATOR'S RESPONSIBILITY to make note of and be aware of all bystanders.

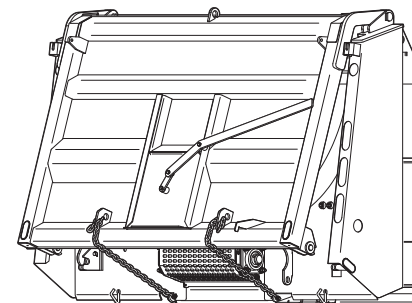

If you are planning to use the spreader chains, fasten them to the appropriate length using the chains and mounting brackets. Set the chains at an equal length.

Tailgate Removal



DANGER: Always observe and follow safe work procedures when lifting heavy objects. Ensure that all bystanders are at a safe distance, and that all necessary lock out and safety precautions are followed.

1. Park the vehicle on a stable and level surface, engage the parking brake, chock the wheels and lock out the machine.
2. Place a strap, chain or cable through the center lifting eye.



WARNING: Ensure that all rigging and lifting implements (crane, hoist, etc...) are appropriately rated to hold the load, as some rear tailgates can weigh up to 800 lbs. (363 kg).

3. Slowly raise the rigging until the cable is taught, and the weight of the tailgate is off the hinges.
4. Remove the tailgate upper pins.
5. Open the lower tailgate hardware by using the tailgate release mechanism (located in-cab)
6. Slowly move the tailgate in an Upward & Rearward direction. Ensure that the upper and lower hinges do not bind or catch.



WARNING: Keep all body parts away from suspended load. **DO NOT** attempt to release an impeded tailgate with bare hands.

7. Lay the tailgate horizontally in a safe area to ensure it does not fall during storage.
8. To replace the tailgate, repeat the above steps in reverse order.

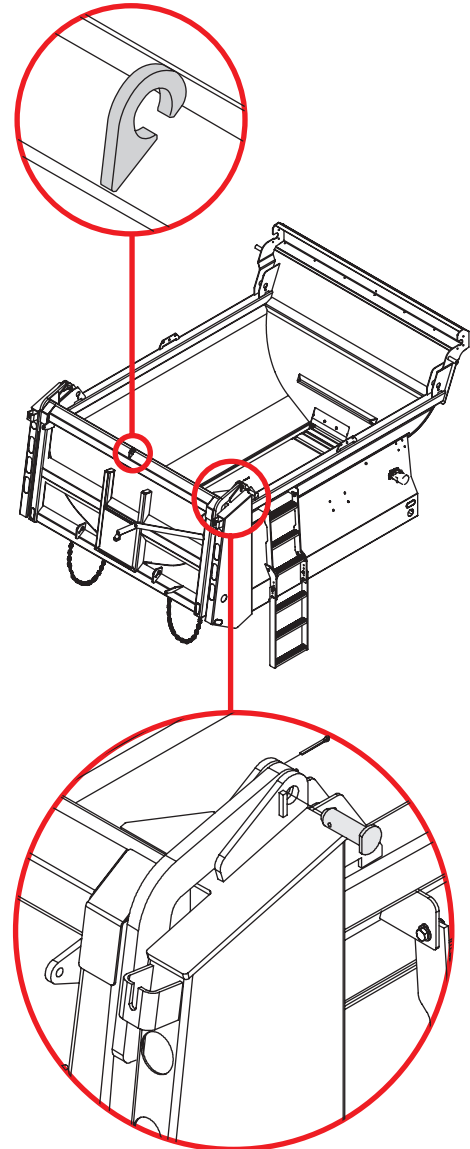

NOTE: Some tailgate hinges will have washers between the hinge plates. Return all washers when re-installing the tailgate. Replace any worn or damaged hinge hardware before replacing the tailgate.



Summer & Winter Configurations



DANGER: NEVER operate the Proline Dual Auger Body without the proper guards in place. Whenever the guards must be removed, replaced or changed, always ensure that the machine is properly locked out. Failure to properly guard the body augers can result in severe injury or death.

Summer Configuration

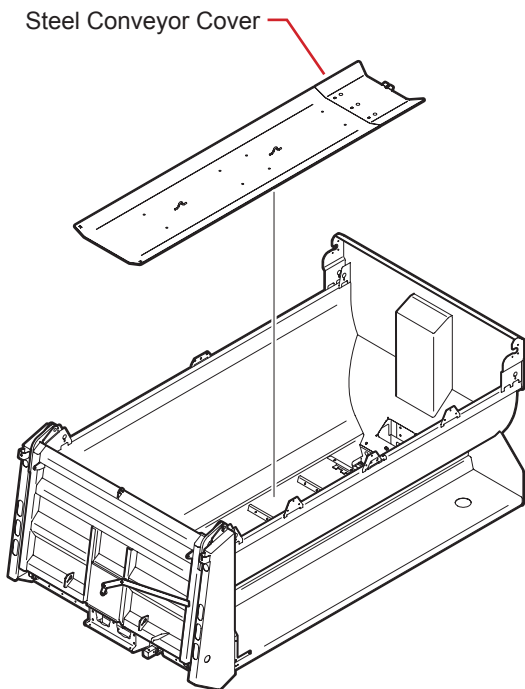

During the summer, when using the Proline body as a dump truck, the **steel conveyor cover** must be in place to properly shield the augers from anything that might become entangled or jammed. The steel guard also protects the auger shafts from damage from coarse materials used in summer road maintenance operations.

Winter Configuration

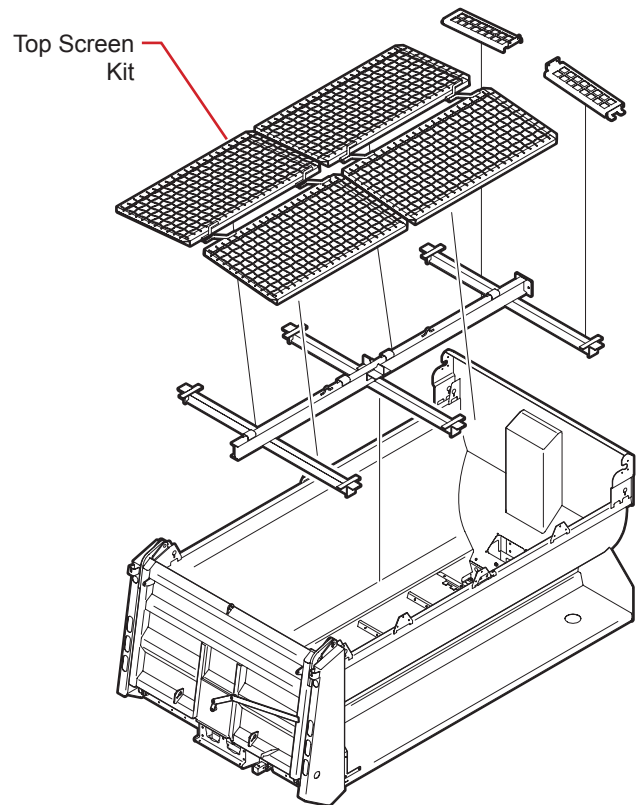

For winter operations, when using sand, salt or other fine materials, the Proline body must have a set of screens in place. The body must always have guarding in place during operation. The guards prevent anything (or anyone) from entering the body that may become entangled or jammed in the augers.



Lockout Procedure

Vehicle lockout procedures are essential in protecting workers while performing maintenance or repairs to the vehicle and its equipment. The purpose of the Lockout Procedure is to recognize, isolate and neutralize all potential sources of energy (electrical, hydraulic or kinetic) and render the equipment safe for all personnel during maintenance or repairs.



DANGER: ALWAYS Follow the proper Lockout Procedure when performing any maintenance to any electrical or hydraulic systems.

Maintenance Safety is the responsibility of the owner, as well as the operator. **A detailed procedure must be established to fit every situation.**

Lockout & Tagout Procedure

1. Park vehicle on a firm, level surface (such as a concrete garage floor or paved area) that is large enough to safely accommodate working on the truck.
2. Lower all attachments to the ground.
3. Apply the vehicle's parking brake, stop the engine and remove keys from the ignition.
5. Notify all affected individuals that they must comply with the lockout procedures.
6. Tag the in-cab controls "Do Not Operate" and notify all affected personnel of the meaning of the tag.

3. Apply the vehicle's parking brake, stop the engine and remove keys from the ignition.

4. With the engine off, relieve all pressure on the hydraulic system by moving the hydraulic levers in both directions.

Relieve all pressure on the pneumatic system by pumping the brakes while the vehicle is off or by opening the release valve on the air tank.



WARNING: When relieving hydraulic and pneumatic pressure, some component movement may occur. Exercise extreme caution when working on pneumatic or hydraulic systems, and keep all bystanders clear while relieving pressure.

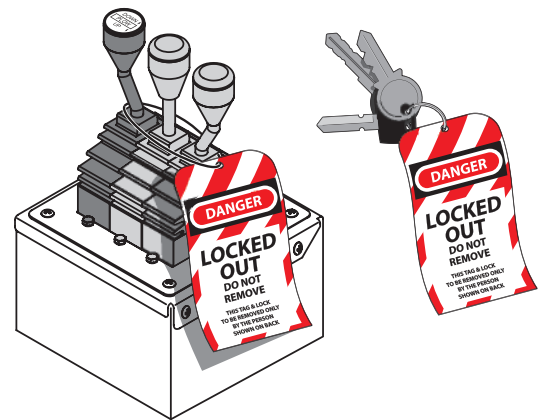

NOTE: Tags should be suited to resist the environment in which they are to be used (oil, sunlight, grease, etc...). Tags must be easily recognizable at the location of the operating controls.

Tags must be standardized by color, shape, size and format.



01303397

AIR TAILGATE INSTALL KIT PL

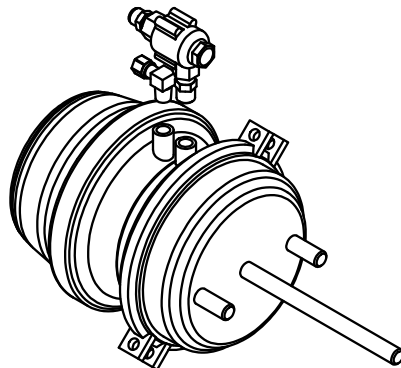
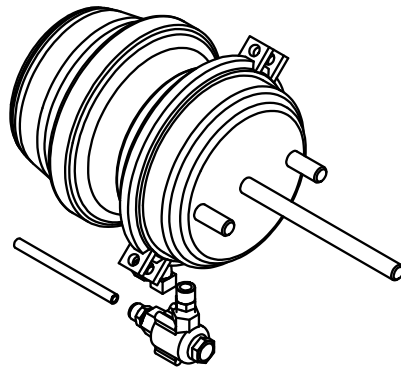
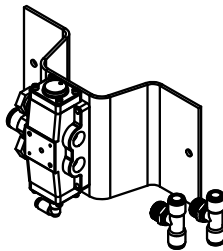
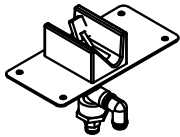

EQUIPMENT MAY NOT BE EXACTLY AS SHOWN. SOME COMPONENTS MAY BE OPTIONAL.
TO MAINTAIN OUR ON-GOING PRODUCT DEVELOPMENT AND IMPROVEMENT PROGRAM, VIKING-CIVES LTD. RESERVES THE RIGHT TO CHANGE EQUIPMENT & SPECIFICATION WITHOUT NOTICE.



01303397

AIR TAILGATE INSTALL KIT PL

ITEM ID	ITEM NO.	DESCRIPTION	QTY REQ
1	0530058	VALVE PRESSURE PROTECTION AIR	1
2	0530176	VALVE BALL 1/4 NPT 1/4 TURN	1
3	0630291	FITTING REDUCER BRASS 3/8 TO 1/4	1
4	0630294	FITTING BRASS 1/4 90 DEG STREET ELBOW	1
5	0630299	AIR BRAKE TUBING 1/2 PROTECTION VALVE	1
6	0630302	FITTING BRASS MALE CONN 1/2 TUBE 1/4 NPT	1
7	0630303	FITTING BRASS HEX NIPPLE 1/4 NPT	2
8	0630333	AIR BRAKE TUBING 1/4	1
9	0630472	FITTING BRASS REDBUSH 1/2 MNPT 3/8 FNPT	1

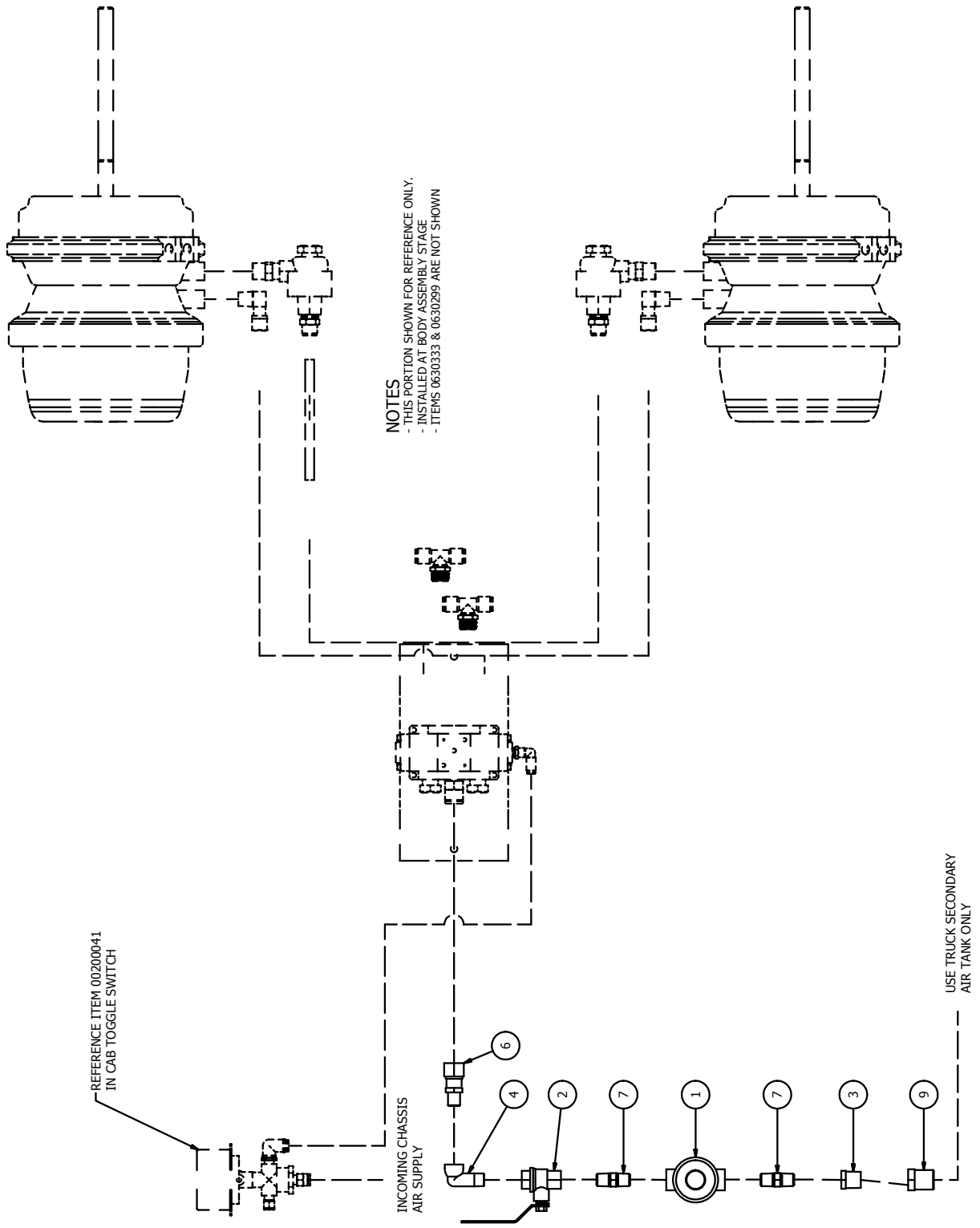

NOTES
 - THIS PORTION SHOWN FOR REFERENCE ONLY.
 - INSTALLED AT BODY ASSEMBLY STAGE
 - ITEMS 0630333 & 0630299 ARE NOT SHOWN

EQUIPMENT MAY NOT BE EXACTLY AS SHOWN. SOME COMPONENTS MAY BE OPTIONAL.
 TO MAINTAIN OUR ON-GOING PRODUCT DEVELOPMENT AND IMPROVEMENT PROGRAM, VIKING-GIVES LTD. RESERVES THE RIGHT TO CHANGE EQUIPMENT & SPECIFICATION WITHOUT NOTICE.



This Page Left Blank
