



OWNERS MANUAL

VCU METRO TRIP EDGE (MTE) REVERSIBLE SNOW PLOW



EQUIPMENT MAY NOT BE EXACTLY AS SHOWN. SOME COMPONENTS MAY BE OPTIONAL.

TO MAINTAIN OUR ON-GOING PRODUCT DEVELOPMENT AND IMPROVEMENT PROGRAM, VIKING-CIVES RESERVES THE RIGHT TO CHANGE EQUIPMENT & SPECIFICATION WITHOUT NOTICE.



INTRODUCTION- VCU METRO TRIP EDGE (MTE) REVERSIBLE SNOW PLOW

CONGRATULATIONS AND THANK YOU FOR YOUR PURCHASE OF NEW VIKING-CIVES SNOW & ICE CONTROL EQUIPMENT. THIS MANUAL HAS BEEN CREATED TO PROVIDE YOU WITH INSTALLATION, SET-UP, OPERATION, AND MAINTENANCE INFORMATION FOR THE VIKING-CIVES **METRO TRIP EDGE (MTE) REVERSIBLE SNOW PLOW**. IT HAS BEEN PREPARED TO FAMILIARIZE YOU OR ANY OTHER PERSON WHO WILL BE ASSEMBLING, OPERATING, MAINTAINING, OR WORKING WITH THIS PRODUCT WITH THE DESIGN FEATURES, AND TO INSTRUCT YOU IN THE RECOMMENDED OPERATION AND MAINTENANCE OF THE UNIT.

READ THIS MANUAL CAREFULLY BEFORE YOU OPERATE OR SERVICE YOUR **METRO TRIP EDGE (MTE) REVERSIBLE SNOW PLOW**. REMEMBER THAT YOU'RE WORKING WITH HEAVY EQUIPMENT THAT CAN INJURE YOU OR SOMEONE ELSE. YOU CAN HELP LESSEN THE CHANCE OF INJURY BY FOLLOWING THE PROCEDURES IN THIS MANUAL, CAREFULLY.

DANGER: IF INCORRECTLY USED, THIS EQUIPMENT CAN CAUSE SEVERE INJURY. YOUR CHANCE OF INJURY CAN BE GREATLY REDUCED BY FOLLOWING ALL SAFETY DECAL NOTIFICATIONS. ALL DECALS MUST BE KEPT CLEAN AND COMPLETE. REPLACE ANY DECALS THAT ARE UNREADABLE. DECALS MAY BE PURCHASED DIRECTLY FROM VIKING-CIVES USA AND/OR YOUR NEAREST AUTHORIZED DEALER. ALL OPERATOR/SERVICE SHOULD REVIEW THIS MANUAL CAREFULLY AND BECOME FAMILIAR WITH ITS CONTENTS. **IF ANYONE ELSE BESIDE YOU OPERATES OR SERVICES THIS EQUIPMENT, MAKE SURE THEY READ THIS MANUAL AND ARE INSTRUCTED TO FOLLOW ALL THE SAFETY PROCEDURES RELATED TO THIS EQUIPMENT. KEEP THIS MANUAL AVAILABLE FOR REFERENCE WHENEVER THIS PRODUCT IS BEING HANDLED OR USED. PROVIDE THIS MANUAL TO ANY NEW OWNERS AND/OR OPERATORS.**

GENERAL OPERATION DESCRIPTION: THE **METRO TRIP EDGE (MTE) REVERSIBLE SNOW PLOW** IS DESIGNED TO PUSH FROM A TRUCK ATTACHING POINT AT APPROXIMATELY 13" FROM THE GROUND. ADJUSTMENTS ARE BUILT INTO THE PLOW AND PUSHFRAME TO ALLOW A SMALL VARIATION IN PUSH HEIGHT.

INSTALLATION

NOTE: THE INITIAL INSTALLATION OF THE PLOW MUST BE PERFORMED ON A REASONABLY SMOOTH AND LEVEL SURFACE TO INSURE PROPER INSTALLATION AND AVOID UNNECESSARY ADJUSTMENT.

ADJUSTING PUSH HEIGHT/PLOW

1. PIN THE PLOW TO THE TRUCK USING THE AVAILABLE PUSHLUG HOLES, FINDING THE POINT NEAREST TO **13"**.
2. INSPECT THE CUTTING EDGE, MOLDBOARD SHOES AND PUSHFRAME SHOES TO SEE IF ALL WEAR POINTS ARE ON THE GROUND.
3. IF ALL WEAR POINTS ARE ON THE GROUND, NO ADJUSTMENT REQUIRED. IF ALL WEAR POINTS ARE NOT IN CONTACT WITH THE GROUND, ADJUST BRACE ARM UNTIL MOLDBOARD SETS FLAT.
4. ADJUST PUSHFRAME SHOES TO SUIT THE BRACE ARM POSITION. **(IF APPLICABLE)**

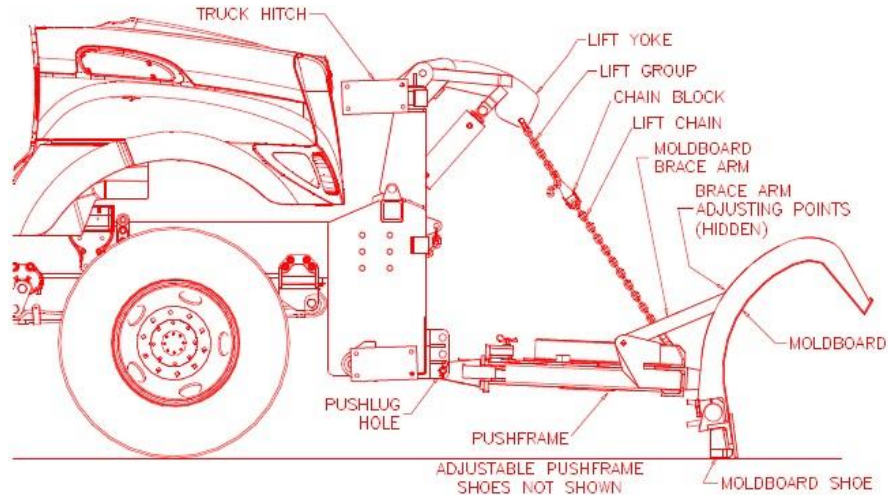

ADJUSTING PLOW ATTACK ANGLE

WARNING!!!!

THE MOLDBOARD MUST BE SUPPORTED BY HOIST OR CHAINFALLS BEFORE REMOVING THE ADJUSTING PINS. WITHOUT A SUPPORT IT WILL FALL OVER. SERIOUS INJURY COULD RESULT.

THE PROPER ATTACK ANGLE OF THE MOLDBOARD CUTTING EDGE IS 10° . THE ANGLE OF THE CUTTING EDGE CAN BE ADJUSTED IN EITHER DIRECTION BY APPROXIMATELY 10° BY CHANGING THE LENGTH OF THE MOLDBOARD BRACE ARMS.

1. WHILE THE MOLDBOARD IS SUPPORTED, ADJUST BRACE ARMS TO ACHIEVE THE DESIRED 10° ATTACK ANGLE. CHECK THE ANGLE WHEN THE BRACE ARMS ARE ADJUSTED BY LOWERING THE MOLDBOARD TO THE GROUND. ONCE THE PROPER ATTACK ANGLE IS REACHED, CHECK THE MOLDBOARD SHOES FOR EVEN CONTACT WITH THE GROUND. **(IF APPLICABLE)**
2. IF MOLDBOARD SHOES DO NOT HAVE EVEN CONTACT WITH THE GROUND AFTER ADJUSTING THE BRACE ARMS, ADJUST THE MOLDBOARD SHOES SO THERE IS EVEN CONTACT WITH THE GROUND TO ENSURE PROPER WEAR. **(IF APPLICABLE)**
3. CONNECT THE LIFT CHAIN TO THE LIFT YOKE GRAB LOOP. CONNECT REVERSING HOSES TO THE APPROPRIATE QUICK DISCONNECTS ON THE A-FRAME.
4. OPERATE THE PLOW LIFT CYLINDER TO CHECK FOR SUFFICIENT CARRYING HEIGHT. **DO NOT ALLOW EXTREME LIFT**, WITH CYLINDER AT FULL STROKE; CUTTING EDGE SHOULD BE ONLY 10" TO 12" FROM THE GROUND. ADJUST LIFT CHAIN AT GRAB LOOP IF NECESSARY. LOWER THE PLOW AND CHECK OPERATION OF THE REVERSING MECHANISM.

WARNING!!!!

BE SURE ALL PERSONNEL ARE WELL CLEAR OF THE PATH OF THE MOLDBOARD AS IT SWEEPS. SERIOUS INJURY COULD RESULT.



OPERATION

WHEN ALL CONDITIONS OF INSTALLATION HAVE BEEN MET, THE PLOW IS READY TO OPERATE. THIS PLOW WAS DESIGNED TO OPERATE IN THE FORWARD PLOWING DIRECTION ONLY. **NOTE: ALWAYS LIFT THE PLOW BEFORE REVERSING THE PRIME MOVER.** THE LEVERS FOR CONTROLLING THE PLOW LIFT AND REVERSE FUNCTIONS ARE LOCATED IN THE CAB OF THE PRIME MOVER.

TO LIFT THE PLOW

THE PLOW LIFT LEVER ACTIVATES A THREE-POSITION VALVE.

1. NORMALLY TO RAISE THE PLOW, PULL THE PLOW LIFT LEVER. WHEN YOU RELEASE THE LEVER THE VALVE WILL RETURN TO A NEUTRAL HOLD POSITION AND THE PLOW WILL REMAIN IN THAT POSITION.
2. TO LOWER THE PLOW, PUSH THE PLOW LIFT LEVER. WHEN YOU RELEASE THE LEVER THE VALVE WILL RETURN TO A NEUTRAL HOLD POSITION AND THE PLOW WILL REMAIN IN THAT POSITION.

NOTE: FOR PLOWS WITH THIS LIFT VALVE ARRANGEMENT, IT IS NECESSARY TO HOLD THE PLOW LIFT LEVER IN THE DOWN POSITION FOR A FEW MOMENTS WHILE PLOWING TO ALLOW THE PLOW TO SEEK ITS LOWEST LEVEL. AFTER THIS HAS BEEN ACCOMPLISHED YOU CAN RELEASE THE LEVER AND THE PLOW WILL PROPERLY SET TO FOLLOW THE CONTOUR OF THE PLOWING SURFACE. HOWEVER, SOME UNITS ARE EQUIPPED WITH A THREE-POSITION PLOW LIFT VALVE WITH A DETENT IN THE DOWN POSITION. THIS VALVE WILL LOCK IN A FLOAT POSITION WHEN THE PLOW IS LOWERED. THE PLOW WILL THEN AUTOMATICALLY SEEK ITS LOWEST LEVEL ALLOWING IT TO FOLLOW THE CONTOUR OF THE PLOWING SURFACE.

TO REVERSE THE PLOW

1. NORMALLY THE PLOW REVERSE LEVER ACTIVATES A THREE-POSITION VALVE. IF YOU PUSH OR PULL THIS LEVER, THE PLOW WILL REVERSE TO THE LEFT OR RIGHT ACCORDINGLY.
2. RELEASING THE LEVER WILL SHIFT THE VALVE INTO A NEUTRAL HOLD POSITION.
3. WHEN SETTING THE PLOW IN EITHER THE RIGHT OR LEFT POSITION, LOWER THE PLOW TO THE PLOWING SURFACE AND PUSH OR PULL THE LEVER ACCORDINGLY UNTIL THE CYLINDER BOTTOMS OUT, THEN BACK IT OFF SLIGHTLY TO ALLOW THE VALVE CUSHION TO WORK PROPERLY.

DO NOT RUN THE PLOW WITH CYLINDERS FULLY RETRACTED

MAINTENANCE

IN PREPARATION FOR THE SNOWPLOWING SEASON AND **AFTER EVERY EIGHT (8) HOURS OF OPERATION**, A VISUAL EQUIPMENT INSPECTION MUST BE PERFORMED. LOOK FOR ANY DAMAGED COMPONENTS, BENDS, CRACKED WELDS, HYDRAULIC LEAKS, ETC. INSPECT ALL FASTENERS; TIGHTEN ANY THAT HAVE LOOSENED AND REPLACE ANY THAT ARE DAMAGED. CHECK ALL HYDRAULIC HOSES FOR CUTS, CRACKS AND/OR LEAKS. CHECK PLOW LIFT CABLE(S) FOR LOOSE CLAMPS AND FRAYS, **IMMEDIATELY REPLACE FRAYED CABLES**. ON PLOWS WITH PUSHFRAME MOUNTED SHOES, CHECK ALL SHOE MOUNTING BOLTS FOR TIGHTNESS AND/OR PROPER ADJUSTMENT. CORRECT SHOE HEIGHT SETUP IS CRITICAL FOR PLOW OPERATION AND PERFORMANCE. INSPECT AND GREASE ALL JOINTED AREAS WITH A GREASE PORT ACCESS TO ENSURE LONGEVITY AND PROPER MOVEMENT OF EQUIPMENT.

PERIODICALLY DURING PLOWING, STOP TO INSPECT PLOW CUTTING EDGES AND MOLDBOARD/PUSHFRAME SHOES FOR WEAR. AT THE FIRST SIGN OF EXCESSIVE WEAR, DISCARD AND REPLACE WITH NEW PARTS.

WHEN THE PLOW IS DISCONNECTED FROM THE PRIME MOVER, BE SURE TO COUPLE THE HYDRAULIC HOSES TOGETHER, TO PREVENT DAMAGE TO THE QUICK DISCONNECT HOSE ENDS AND TO HELP PREVENT THE INTRODUCTION OF FOREIGN MATERIAL INTO THE HYDRAULIC SYSTEM.