



Roller-Pro Dump Box

The North American Leader in innovative snow & Ice control equipment.



Standard Features

1. **Easy loading onto Roller-Pro Tipping Frame.** Flat ground loading capability empty or full.
2. **Dual Function Tailgate** is top hinged for dumping and side hinged for barn door operation.
3. **Single Action Handle** switches between dumping and barn-door tailgate operation.
4. **Durable 10 gauge Corten Construction** resists material wear and corrosion.

Options

- Hardox floor and sides
- 36" or 42" side height
- D -Rings for load and equipment tie-down
- Air tarp kit

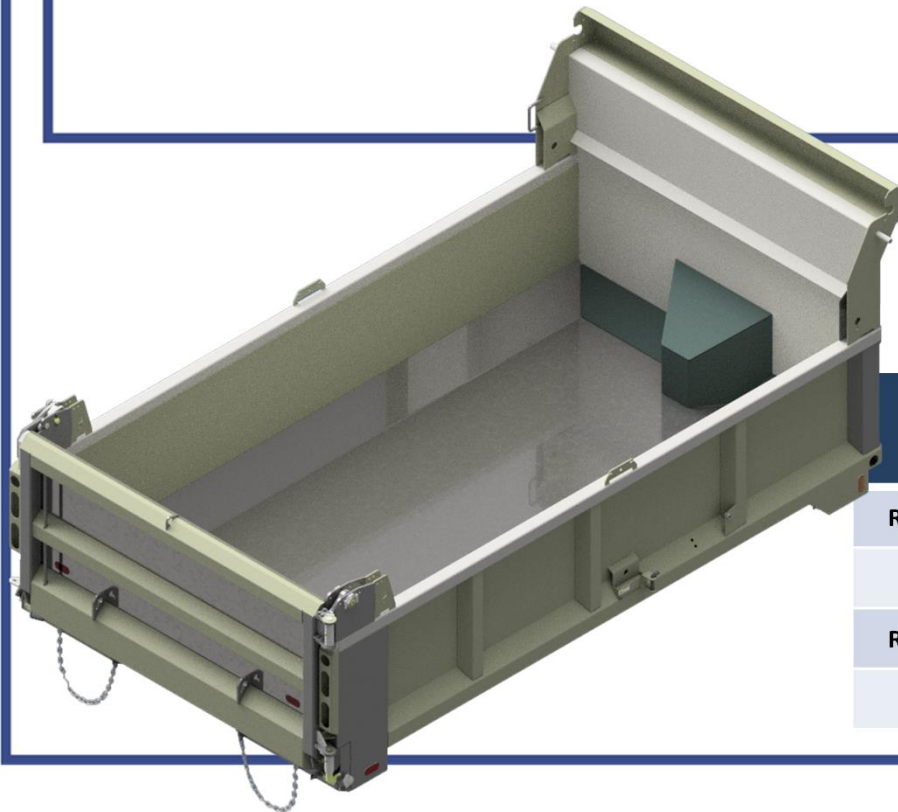

Model	Outside Length	Side Height	Tailgate Height	Capacity *w/sideboards	Approx . Weight
RPDB 120	14'4"	36"	46"	14.5 yd3	4860 lbs
	14'4"	42"	55"	16.5 yd3	5130 lbs
RPDB 138	16'	36"	46"	16.4 yd3	5260 lbs
	16'	42"	55"	18.6 yd3	5520 lbs