



VCL 350 SCL Cable Tower

The North American
Leader in innovative
snow & ice control
equipment.

Standard Features

1. Integral Back-of-Cab Oil Tank with in tank return filter.
2. Cable Rear Lift.
3. Vertical Wing Arm Slide for benching and shelving.
4. Manual Extension Wing Arm allows the clearing path to be increased or decreased.
5. Front Tower Trip Hinge controlled by torsion spring.

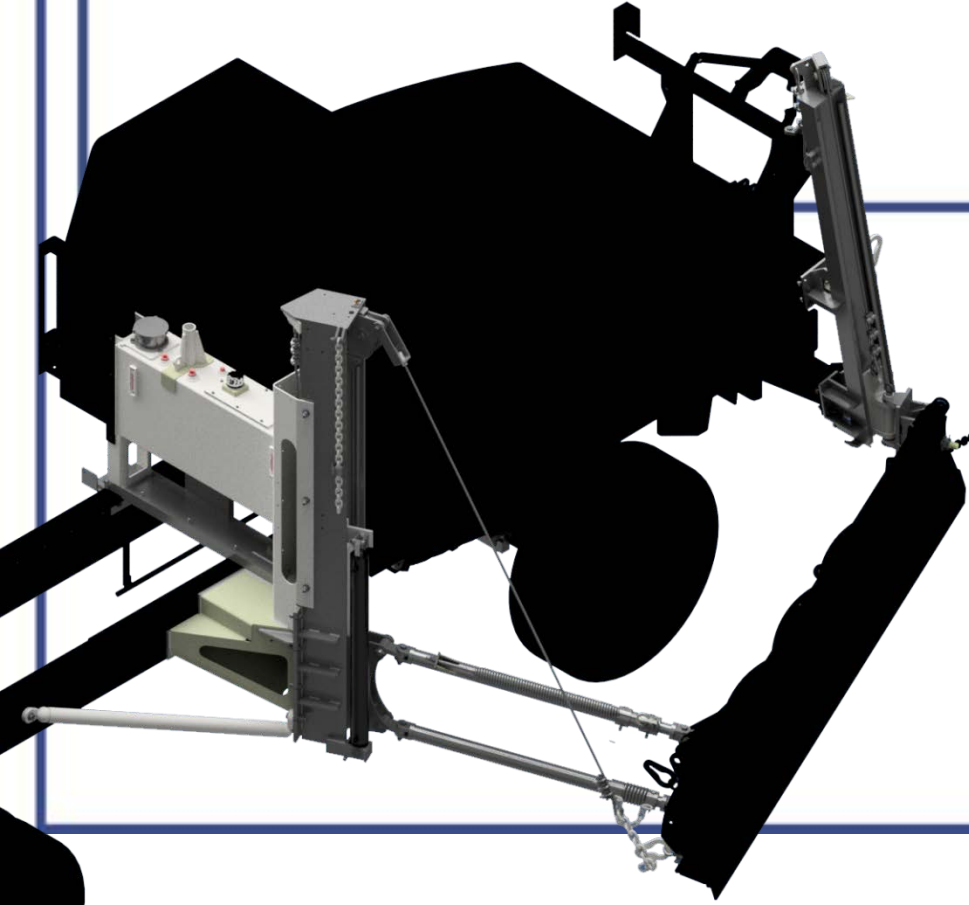

Options

- Horizontal wing positioner
- Hydraulic quick disconnect options
- Wing light and markers for safety

