

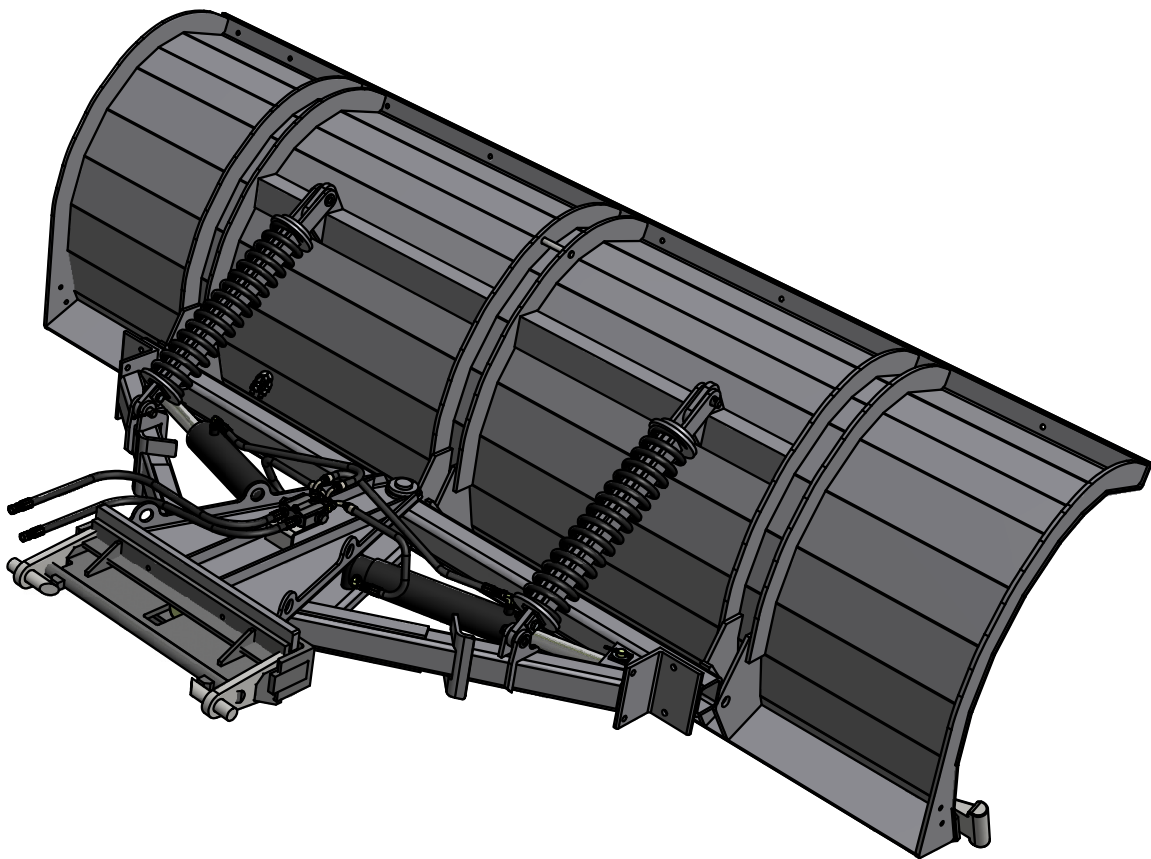

OWNER'S MANUAL

VCL POWER REVERSING FE PLOW



EQUIPMENT MAY NOT BE EXACTLY AS SHOWN. SOME COMPONENTS MAY BE OPTIONAL.
TO MAINTAIN OUR ON-GOING PRODUCT DEVELOPMENT AND IMPROVEMENT PROGRAM, VIKING-CIVES LTD. RESERVES THE RIGHT TO CHANGE EQUIPMENT & SPECIFICATION WITHOUT NOTICE.



INTRODUCTION - VCL POWER REVERSIBLE FE PLOW

Congratulations and thank you for your purchase of new Viking-Cives Snow & Ice Control equipment. This manual has been created to provide you with installation, set-up, operation and maintenance information for the Viking-Cives **VCL Power Reversible FE Plow**. It has been prepared to familiarize you or any other person who will be assembling, operating, maintaining, or working with this product with the design features, and to instruct you in the recommended operation and maintenance of the unit.

Read this manual carefully before you operate or service your **VCL Power Reversible Plow**. Remember that you're working with heavy equipment that can injure you or someone else. You can help lessen the chance of injury by following the procedures in this manual, carefully.

DANGER: If incorrectly used, this equipment can cause severe injury. Your chance of injury can be greatly reduced by following all safety decal notifications. All decals must be kept clean and complete. Replace any decals that are unreadable. Decals may be purchased directly from Viking-Cives Group and/or your nearest authorized dealer. All Operator/Service people should review this manual carefully and become familiar with its contents. **If anyone else beside you operates or services this equipment, make sure they read this manual and are instructed to follow all the safety procedures related to this equipment. Keep this manual available for reference whenever this product is being handled or used. Provide this manual to any new owners and/or operators.**

INSTALLATION

TO CONNECT TO PRIME MOVER

During the initial installation of the plow to the vehicle, some adjustments will be necessary to insure proper operation of the plow and trip mechanisms. It is Viking-Cives recommendation that the plow is set to run at an approach angle from the road surface of approximately 75 degrees, as shown in Figure 1. **NOTE: When plow is being raised, lowered or reversed - stand clear!**

1. Set plow unit on level surface with moldboard in the bulldoze position; adjust drive height to approximately 21" as shown in figure 1.
2. Drive the prime mover into position. connect the plow drive frame to the vehicle push harness. **NEVER stand between the prime mover and the plow drive frame when the vehicle is being moved into position.** Before connecting the drive frame to the push harness, shut the vehicle engine down and make sure that the auxiliary brake is engaged.
3. Adjustable push frame shoes, if equipped. The normal setting is to have the shoes and the cutting edge touch the plowing surface at the same time, though plowing conditions may require other settings.

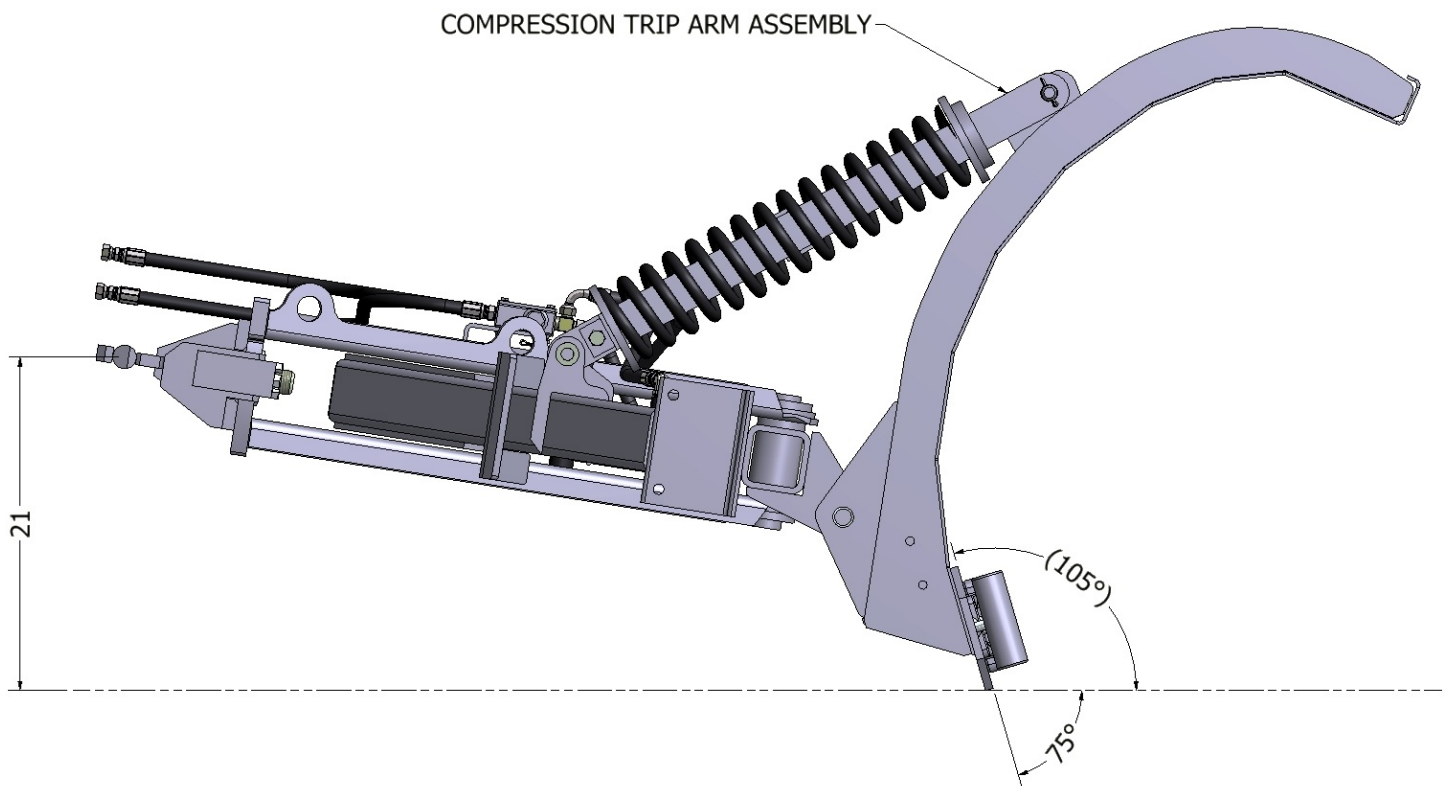

FIGURE 1: DRIVE HEIGHT SETTINGS

TO CONNECT HYDRAULICS FOR REVERSING CYLINDERS

Connect the hydraulic hoses leading from the cushion valve located on the plow drive frame to the quick disconnect couplers located on the prime mover. NOTE: Normally one hose will have a male quick connect hose end and the other will have a female quick disconnect hose end. This prevents the hoses from being coupled incorrectly. Also, when the hoses are disconnected from the prime mover this allows for them to be coupled together to prevent contamination from entering into the hydraulic system. Carefully raise the plow blade and cycle the reversing cylinders to check hose clearances and to check for any interference. Cycle the cylinders several times from fully retracted to fully extended position until all air has been completely removed from the cylinders.

NOTE: Plow lift and power reverse functions should be thoroughly tested BEFORE operating the plow in a working situation.



09701211

PUSHFRAME ASS'Y VCL POWER REV FE PLUMBING

ITEM ID	ITEM NO.	DESCRIPTION	QTY REQ
1	01501231	HOSE HYD 1/2 100R2 0630114-56-0630121	2
2	01501232	HOSE HYD 1/2 100R2 0630121-32-0630126	2
3	01501233	HOSE HYD 1/2 100R2 0630121-25-0630126	2
4	0530029	VALVE CUSHION DXV-50-1200	1
5	0540026	CYLINDER HYD DA 3 1/2 X 15	2
6	0630095	HYDRAULIC RUN TEE 1/2 MNPT 1/2 JIC	2
7	0630099	HYD ADAPTER 1/2 ORB 90 1/2 JIC	4

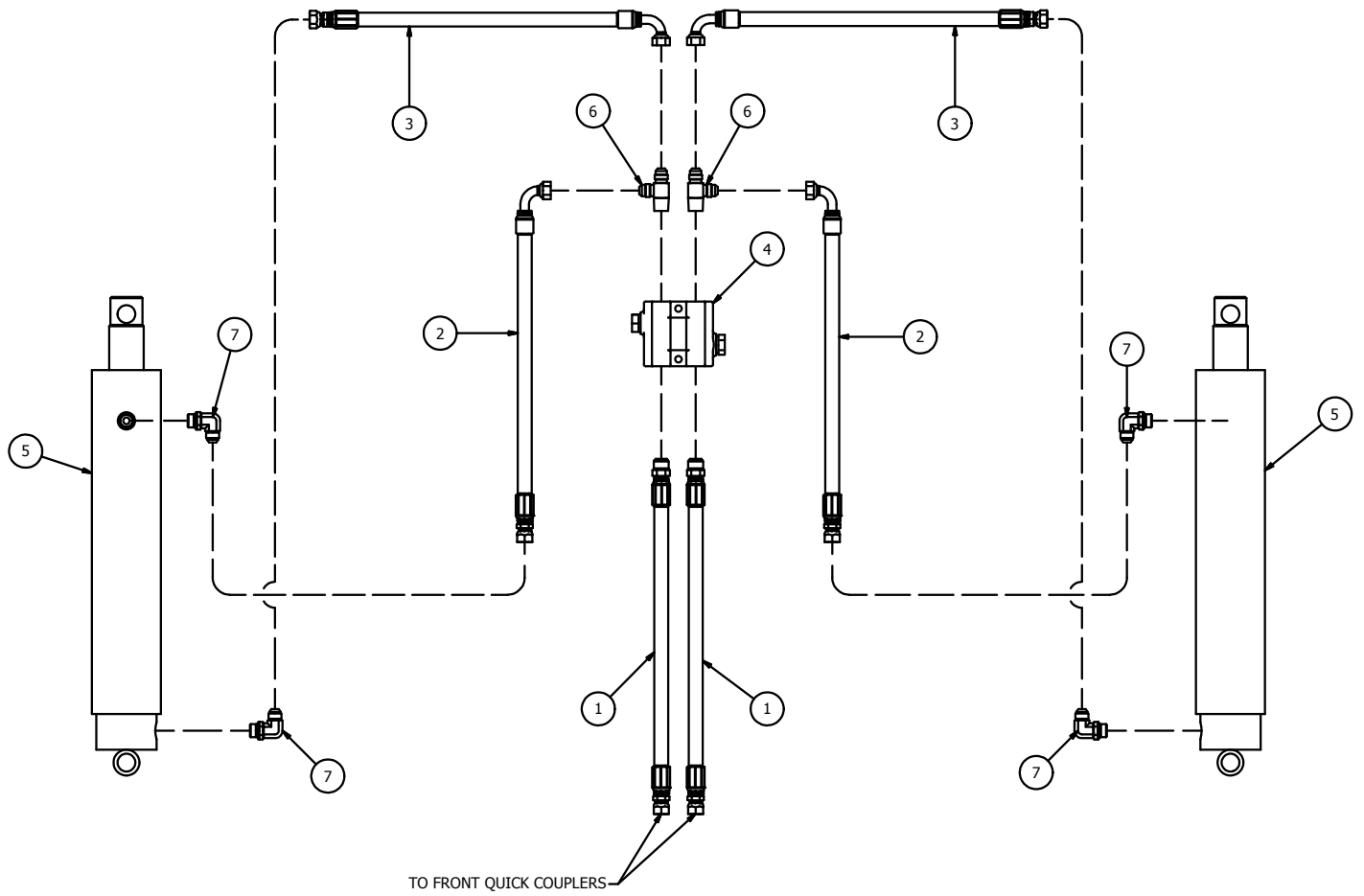



OPERATION

When all conditions of installation have been met, the plow is ready to operate. This plow was designed to operate in the forward plowing direction only. **NOTE: Always lift the plow before reversing the prime mover.** The levers for controlling the plow lift and reverse functions are located in the cab of the prime mover.

TO LIFT THE PLOW

The plow lift lever activates a three-position valve. Normally to raise the plow, pull the plow lift lever. When you release the lever the valve will return to a neutral hold position and the plow will remain in that position. To lower the plow, push the plow lift lever. When you release the lever, the valve will return to a neutral hold position. **NOTE:** For plows with this lift valve arrangement, it is necessary to hold the plow lift lever in the down position for a few moments while plowing to allow the plow to seek its lowest level. After this has been accomplished you can release the lever and the plow will be properly set to follow the contour of the plowing surface. However, some units are equipped with a three-position plow lift valve with a detent in the down position. This valve will lock in a float position when the plow is lowered. The plow will then automatically seek its lowest level allowing it to follow the contour of the plowing surface.

TO REVERSE THE PLOW

Normally the plow reverse lever activates a three-position valve. If you push or pull this lever, the plow will reverse to the left or right accordingly. When you release the lever the valve will shift to a neutral hold position. Therefore, you have an infinite variety of plowing angles at your disposal. When setting the plow in either the right or left position, lower the plow to the plowing surface and push or pull the lever accordingly until the cylinder bottoms out, then back it off slightly to allow the valve cushion to work properly. **Do not run the plow with cylinders fully retracted.**

MAINTENANCE

In preparation for the snowplowing season and **after every eight (8) hours of operation**, a visual equipment inspection must be performed. Look for any damaged components, bends, cracked welds, hydraulic leaks, etc. Inspect all fasteners; tighten any that have loosened and replace any that are damaged. Check all hydraulic hoses for cuts, cracks and/or leaks. Check plow lift cable(s) for loose clamps and frays. **Immediately replace frayed cables.** On plows with pushframe mounted shoes, check all shoe mounting bolts for tightness and/or proper adjustment. Correct shoe height setup is critical for plow operation and performance.

Periodically during plowing, stop to inspect plow cutting edges and moldboard/pushframe shoes for wear. At the first sign of excessive wear, discard and replace with new parts.

When the plow is disconnected from the prime mover, be sure to couple the hydraulic hoses together, to prevent damage to the quick disconnect hose ends and to help prevent the introduction of foreign material into the hydraulic system.