

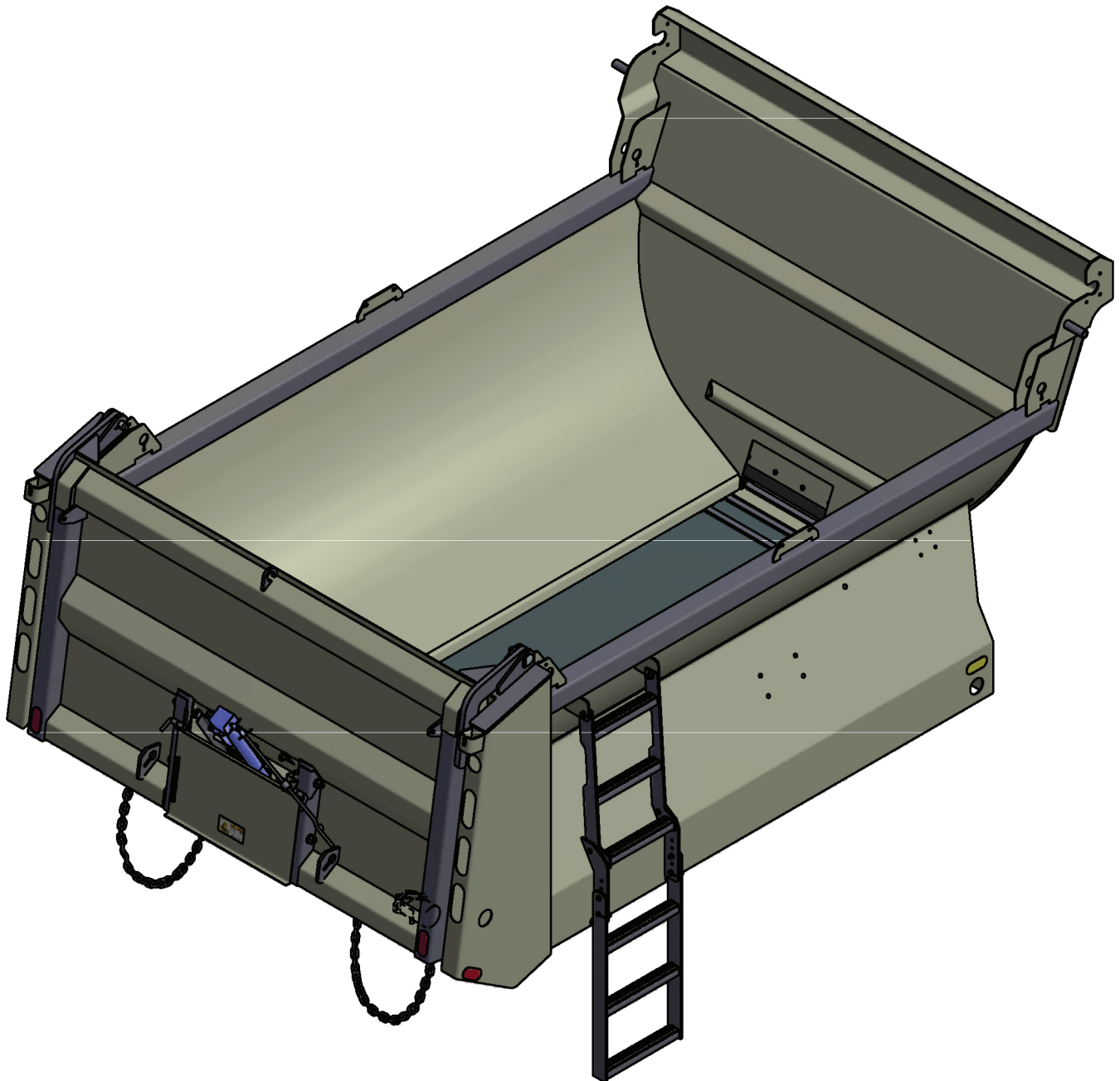

# Owners Manual

## Proline Lightweight-II (PLLW-II)





## Proline Combination Spreader Model Codes

All Pro-Line Combination Spreaders have an associated model code, which identifies the style, type and length of body. The model codes used to describe a Pro-Line Combination Spreader can be broken down as follows:

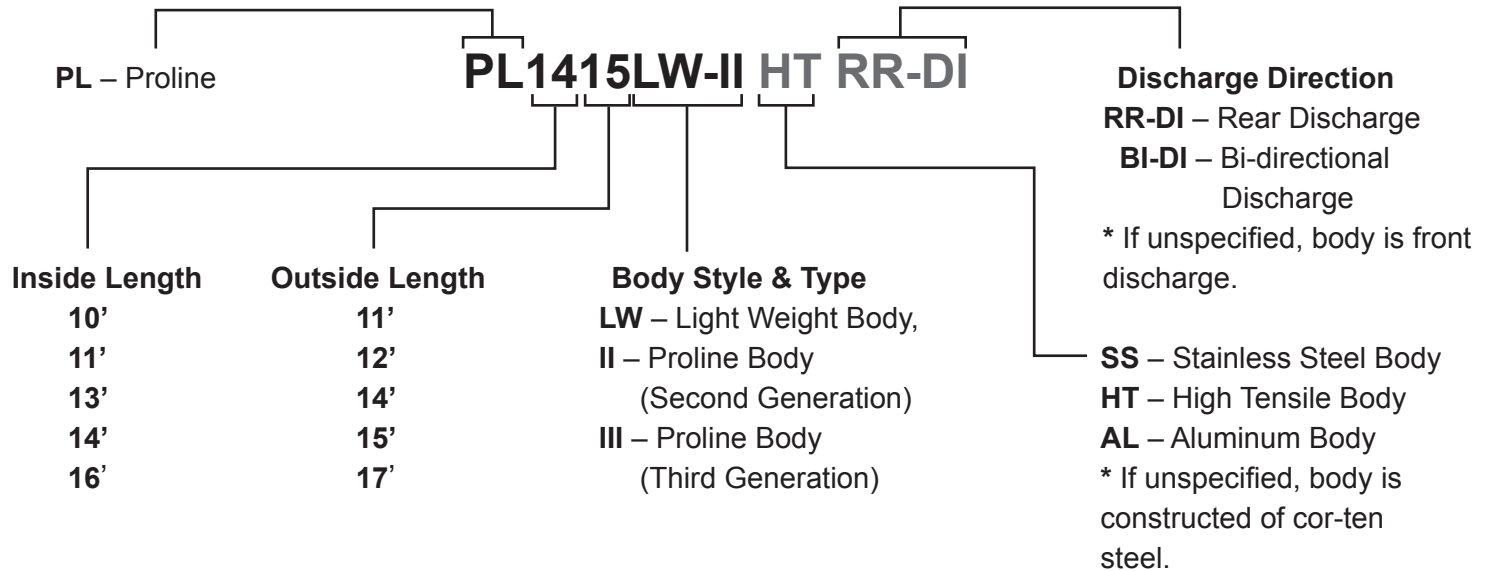

## PLLW-II Combination Spreader Capacities

The Proline Combination Spreader is designed to handle a wide range of material for spreading needs. Some of the materials commonly used in Proline Combination Spreader include:

- Sand & salt for snow & ice control
- Light gravel for general contractor duties
- Hot tar & asphalt

Approximate Capacities of Proline Lightweight Combination Spreaders:

Body Length	Water Level Capacity	Capacity with 10' Sideboards	Side Height	Inside Overall Length	Outside Overall Length
PL1011LW-II	6.0 cu. yds.	8.1 cu. yds.	38"	120 3/4"	132 3/4"
PL1112LW-II	6.6 cu. yds.	9.0 cu. yds.	38"	132 3/4"	144 3/4"
PL1314LW-II	9.9 cu. yds.	12.7 cu. yds.	45"	159 3/4"	171 3/4"
PL1415LW-II	10.7 cu. yds.	13.7 cu. yds.	45"	171 3/4"	183 3/4"
PL1617LW-II	12.3 cu. yds.	15.8 cu. yds.	45"	195 3/4"	207 3/4"

## Body Prop Safety Precautions



**DANGER:** When servicing the area under the raised body, ensure the following:

- Truck is on solid, level ground.
- The dump body is completely emptied of all material (salt, gravel, asphalt, etc...)
- Raised body is supported by the safety prop pins in the upright position.
- Hoist control lever is in the neutral position.
- PTO is disengaged and the unit is in lockout.

**Never** attempt service under the raised dump body alone, failure to do so will result in serious injury or death.

## Raising Dump Body & Supporting With Prop Pins

**To raise and secure dump body, follow these steps:**

Raise dump body to 30°-40° (degrees), and place hoist valve in neutral (hold) position.

Remove body prop pins from storage location and insert into holes located on each side in front of dump hinge.

Before lowering dump hinge reinstall hairpin locking body pins in place.

Lower body slowly until profiled hinge block contacts the prop pins.

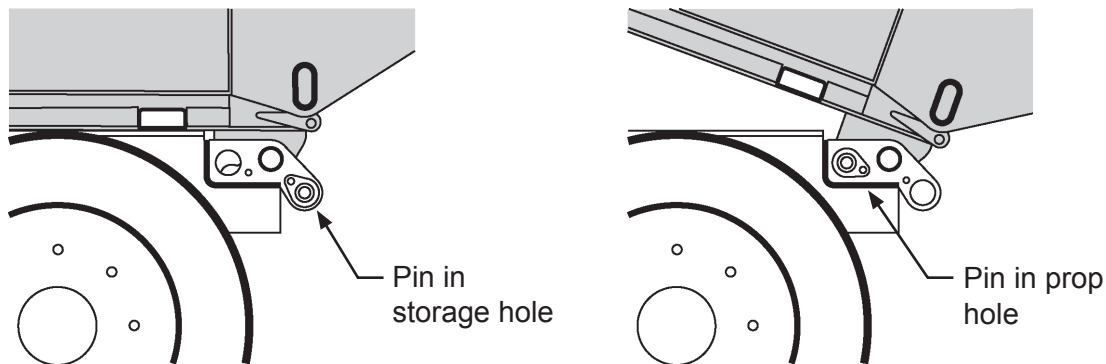

**To remove Prop Pins:**

1. Raise the dump body sufficiently to take load of prop pins, and place hoist control valve in neutral (hold) position.
2. Remove pins from prop holes on both sides and return to storage location provided. **Before lowering body be sure that area below box is completely clear.**
3. Lower body to rest on chassis frame rails.

**Alternate Blocking Method:**

1. Railway tie or piece of wood approximately 6"x6"x5' to lay across frame rails just ahead of dump hinge and extended approximately 1 ft. each side of frame.
2. Place two, 4" X 4" blocks approximately 5' long between tandem tires and block securely against body underside.



## Proline Safety Decal Kit - ANSI Z535.3

0820112



### SAFETY PRECAUTIONS DECALS AND MESSAGES

Before you start operating your Proline Combination Spreader, familiarize yourself with the following safety precautions. Owners, ensure that all operators are familiar safety decals and proper procedures. Failure to follow proper operating instructions, may result in serious injury or death.

The following illustrations show the Viking-Cives Group **Caution**, **Warning** and **Danger** decals. Following the illustrations, you will find a listing of the caution and warning decals with item numbers and a drawing showing the decals location.

### SAFETY INSTRUCTIONS

1. Do NOT use this equipment before reading and understanding the operator's manual.
2. Do NOT lift dump body when truck is moving.
3. The opening control of the rear gate must be locked when the truck is moving.
4. The truck must be in a stable position before starting to lift the dump body.
5. Do NOT tip on recently excavated ground or in filling ground if the soil is not properly compacted.
6. When lifting or dumping, the user must at all times be in control of the operation.
7. The rear gate must be released before starting to lift the dump body.
8. Nobody should stand in the cylinder's operation area when in action.
9. Before dumping, make sure nobody stands in the area.
10. Before starting the spreading mechanism, make sure nobody stands near the spreader.
11. Never stand inside the dump body when the conveyor is in operation.
12. Before starting the spreader, make sure that the outflowing gate is open.
13. When the dump body is not in operation, it must at all times lay on the truck frame.
14. When truck is not in use, remove keys from ignition.
15. When using the dump body as a spreader, use screens for loading.

0820102

0820102

### SAFETY INSTRUCTIONS



**COMPLETELY UNLOAD BODY PRIOR TO USING PROP TO USE PIN TYPE BODY PROP:**

1. Raise body 30 to 40 degrees. Place hoist control valve in neutral (Hold) position.
2. Remove body prop pins from storage location and insert into holes located on each side in front of dump hinge.
3. Before lowering dump hinge re-install hairpin locking body prop pin in place.
4. Lower body slowly until profiled hinge block contacts the prop pins.

**TO REMOVE PIN TYPE BODY PROP:**

1. Raise body sufficiently to take load off of prop pins. Place hoist control valve in neutral (Hold) position.
2. Remove pins from both sides and return to storage location. Before lowering body be sure that area below box is clear.

0820103

## Proline Safety Decal Kit - ANSI Z535.3

0820112



0820097



0820093



0820098



0820101



0820108

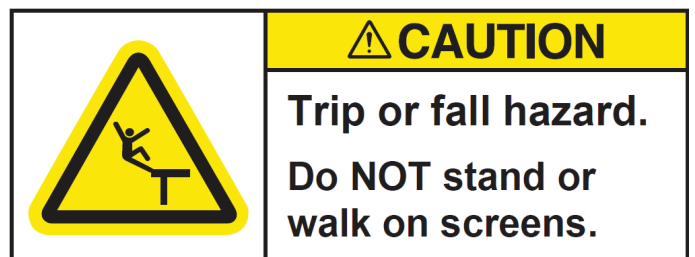

0820096

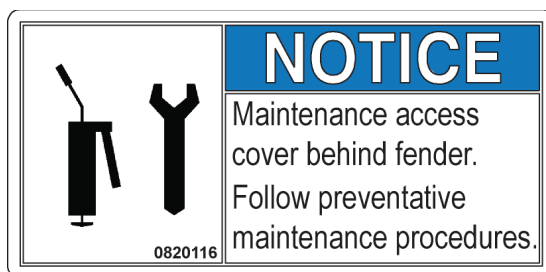

0820116

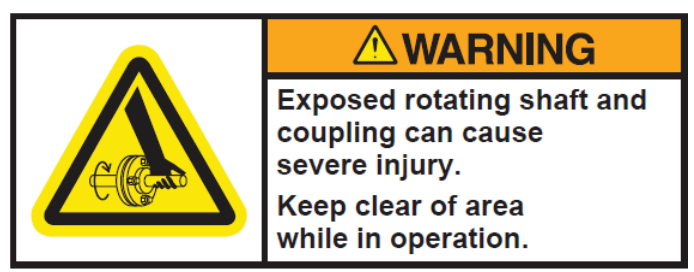

0820107

## Proline Safety Decal Kit - ANSI Z535.3

0820112



0820094

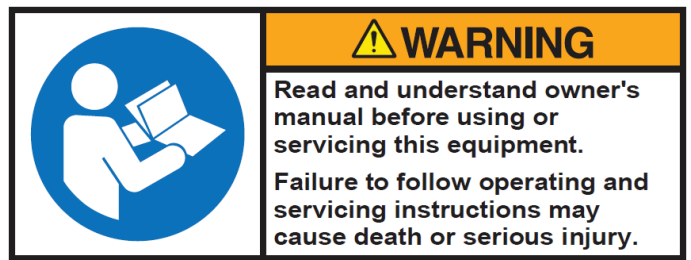

0820099

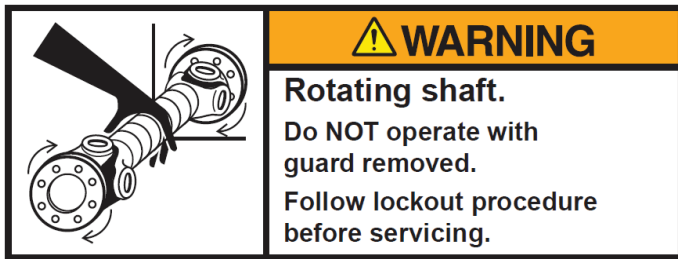

0820100



0820092

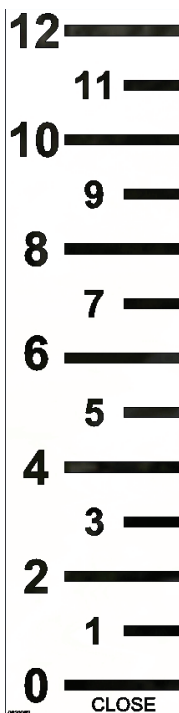

0820052

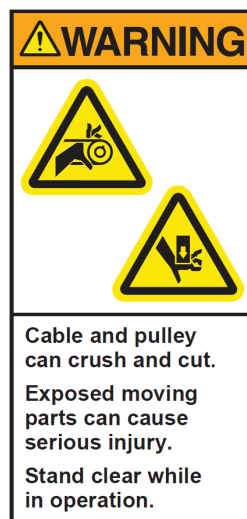

0820109

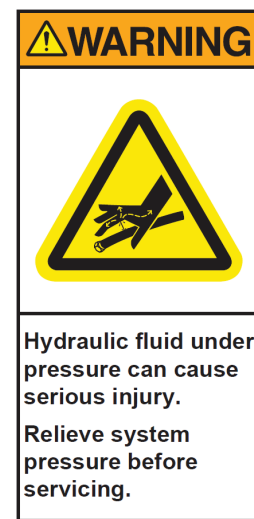

0820095



This Page Left Blank





0820112: DECAL KIT PROLINE SAFETY ANSI Z535.3

ITEM ID	ITEM NO.	DESCRIPTION	QTY REQ
1	0820102	DECAL SAFETY INFO PROLINE	2
2	0820103	DECAL SAFETY INSTRUCT PROPS	2
3	0820097	DECAL DANGER FALLING BODY	4
4	0820093	DECAL DANGER WING	2
5	0820098	DECAL DANGER ENTER BODY	1
6	0820101	DECAL CAUTION BEHIND TRUCK	2
7	0820108	DECAL WARNING PINCH POINT	5
8	0820096	DECAL CAUTION SCREENS	1
9	0820116	DECAL NOTICE MAINTENANCE ACCESS	2
10	0820107	DECAL WARNING ROTATING SHAFT	2
11	0820094	DECAL CAUTION SPINNER	2
12	0820095	DECAL WARNING HYD PRESSURE	2
13	0820100	DECAL WARNING ROTATING SHAFT	1
14	0820099	DECAL WARNING READ MANUAL	1
15	0820052	DECAL GATE DOOR HEIGHT	1
16	0820109	DECAL WARNING WING POST	2
17	0820092	DECAL WARNING CHAIN	3





BOX 1120, NORPARK DRIVE, MOUNT FOREST, ONT. NOG 2L0 (519)323-4433 PH (519)323-4608 FX

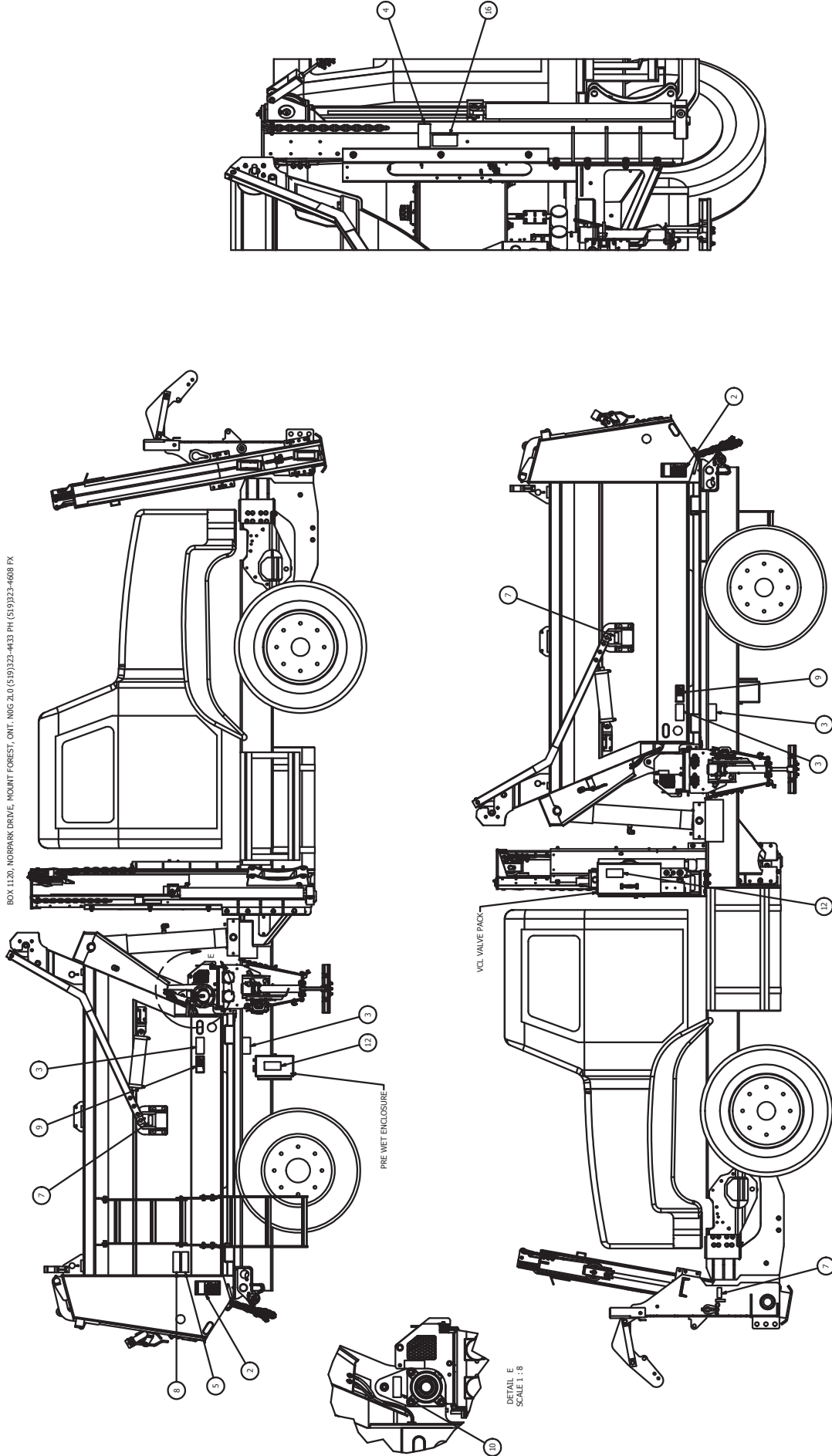

WE RESERVE THE RIGHT TO MAKE ANY CHANGES TO THE PRODUCT WITHOUT NOTICE. WE RESERVE THE RIGHT TO CHANGE EQUIPMENT & SPECIFICATION WITHOUT NOTICE.



BOX 1120, NORPARK DRIVE, MOUNT FOREST, ONT. N0G 2L0 (519)323-4433 PH (519)323-4608 FX

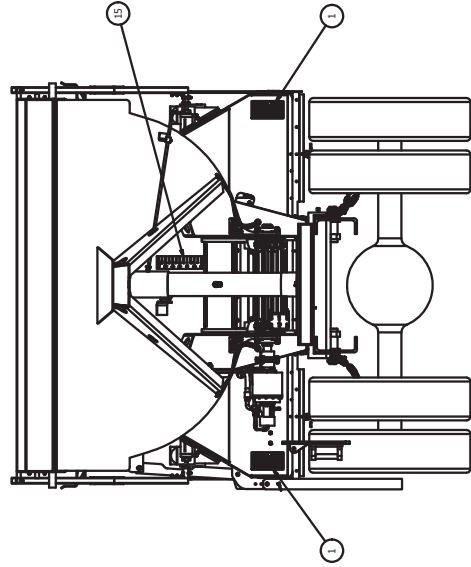
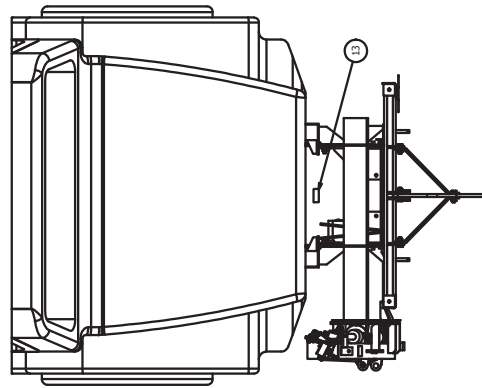
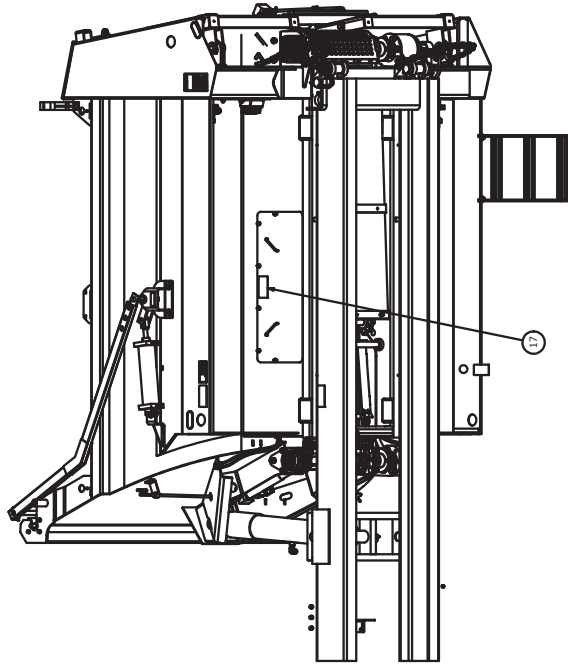
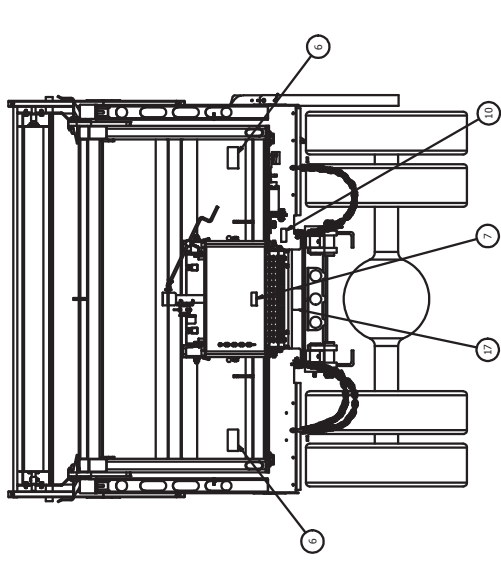
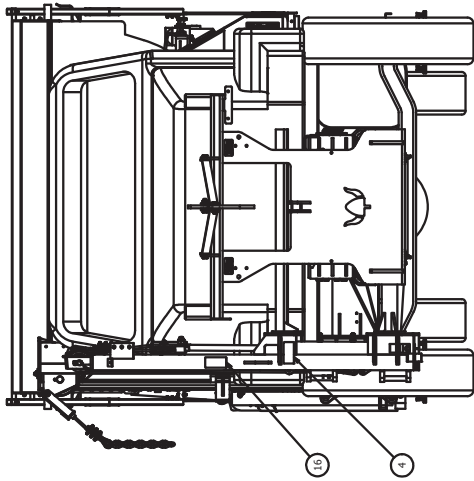

TO MAINTAIN OUR ONGOING PRODUCT DEVELOPMENT AND IMPROVEMENT PROGRAM, WE RESERVE THE RIGHT TO CHANGE EQUIPMENT & SPECIFICATION WITHOUT NOTICE.



BOX 1120, NORPARK DRIVE, MOUNT FOREST, ONT. N0G 2L0 (519)323-4433 PH (519)323-4608 FX

## CROSS CONVEYOR DECAL LOCATIONS

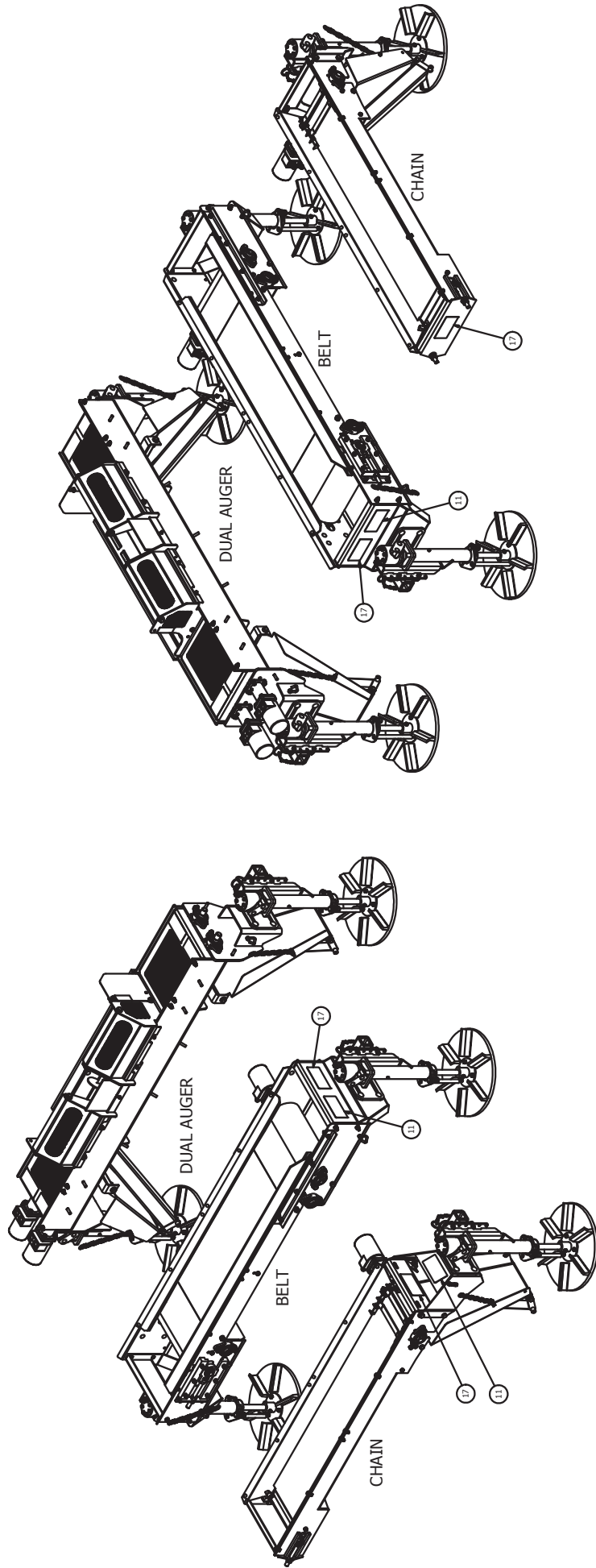

WE STRONGLY RECOMMEND THAT YOU CONTACT US FOR THE LATEST INFORMATION ON PRODUCT DEVELOPMENT AND IMPROVEMENT PROGRAMS. WE RESERVE THE RIGHT TO CHANGE EQUIPMENT & SPECIFICATION WITHOUT NOTICE.



---

# Maintenance

## Preventive Maintenance Inspection & Lubrication

Proper maintenance of your Proline Combination Spreader is essential for a long service life, as well as ensuring that the equipment performs optimally. The maintenance procedures outlined will aid your Proline Combination Spreader in performance and longevity.



**CAUTION:** Before any adjustment, service or maintenance is performed on the spreader, ensure to understand and follow all safety rules:

- Keep all shields and guards in place when operating this equipment.
- Adjust and lubricate spreader, only when the power source is off and locked out.
- The drive shafts, conveyor, and spinner assemblies transmit great amounts of power, and are hazardous when in operation. All maintenance, inspections, or operator adjustments must be made with all source power off.
- When the spreader becomes clogged, shut off the power source and lock it out before attempting to clear the blockage.
- Keep hands, feet and clothing away from moving parts and pinch points.

## Maintenance Schedule



Adjust



Check/Inspect



Replace



Lubricate

## Daily Inspection

Daily inspection, along with preventive maintenance will reduce the chance of major repairs and down time during equipment use.





## Initial Maintenance

During the first weeks of use, operating forces may cause hardware to loosen as the new machine is subjected to exceptional forces. Additionally, Hydraulic oils break down quickly and become contaminated as debris from manufacturing processes. Initial maintenance is paramount to the efficient operation and service life of the plow.

### First 20 Hours of Operation

 Inspect for loose bolts, pins, conveyor chains, and tighten/adjust as required.

 Inspect hydraulic fluid for contamination and level. Add fluid or change as needed.

 Thoroughly lube all mechanical parts – bearings, hoist mounting, chains, and adjusters.

 Inspect main conveyor gearbox oil for contamination and level. Oil sample should be taken from the oil level hole, not the drain hole.

 Change hydraulic system filter(s).

### First 50 & 100 Hours of Operation











 Change main conveyor planetary gearbox gear oil.

**NOTE:** Never mix mineral and synthetic oils in gearbox. Viking-Cives Group recommends using an antifoaming gear oil grade SAE80/90EP.



## Regular Maintenance

### Daily Maintenance

-   Check the fluid level in the hydraulic oil reservoir. If the sight indicates low oil level, add the appropriate amount of the specified hydraulic fluid.
-   Visually Inspect all fasteners. Tighten or replace, if necessary.
-   Visually inspect all hydraulic connections and hoses for cracks and/or leaks. Rupturing hoses may produce a high-pressure stream of hot hydraulic oil.
-  At the beginning of each shift visually inspect all caution and warning decals. All decals should be complete and legible. If decals are not legible, clean them. If cleaning the decals does not make them legible, install new decals.
-   Inspect conveyor chains and tailgate locking mechanism. Adjust as required.
-  Check all conveyor beds for excessive wear or damage.



Clean unit - Empty unit & wash all areas clean of salt and road dirt to prevent corrosion.



## Weekly Maintenance

 Grease all required components at the beginning of each season, then once a week.

- Main conveyor,      • Hoist cylinder mounts
- Cross conveyor      • Tailgate hinges
- Spinner bearings    • Dump hinge

  Check all conveyor chains, chain covers, sprockets, and conveyor beds for excessive wear or damage. Adjust conveyor chains and tailgate locking as required.

 Oil conveyor chains frequently, with an anti-corrosive lubricant every 5 working days and once monthly off-season.



- Hoist Cylinder:

- a. Hoist bottom bushing (1)
- b. Hoist top bushing (1)



- Main Body Assembly:

- a. Main conveyor drive shaft (2)
- b. Main conveyor idler shaft (2)
- c. Dump hinge pin (2)
- d. Tailgate hinge pin (2)
- e. Front gate screw jack (1)
- f. Main conveyor tensioner (4)

## Monthly Maintenance



  Check bolt tightness at valve, cab controls, body guides, and drive shaft bearings.

 Check structural welds at dump hinge, hoist frame and body for cracks due to fatigue or overload.

  Inspect conveyors for possible wear; check set screws/bolts for tightness on sprockets, glider blocks, and gearbox coupler.

 Inspect hydraulic fluid color for possible contamination. If oil appears thick or dirty, drain and replace fluid/filter(s).

**NOTE:** Excessive foaming can be an indication of air and/or moisture presence in the hydraulic system.



  Check for oil leaks in all hydraulic fittings and hoses. Re-tighten and/or replace fittings and hoses as required.









## Mid-Season Maintenance



 Replace hydraulic system return oil filter (10-micron absolute) element.

  Inspect oil(s) for contaminants in conveyor gearbox and hydraulic reservoir. Replace oil(s) and all filters if excessive dirt or metallic particles are evident.

## End of Season Maintenance

  Inspect sprockets, chains, chain covers, bearings, and shafts for wear or damage.

  Visually inspect the tensioning rollers annually to ensure they are intact and aligned, allowing the chain to roll smoothly.

  Check conveyor sprocket teeth for excessive wear annually.

### Storage

Remove spinner(s) inspect bearings, couple hoses on spinner and on truck.

Thoroughly wash down conveyor chains and conveyor beds, and lubricate each

Empty salt or corrosive materials in the body during the off-season.

Lubricate conveyor and cross conveyor chain with an anti-corrosive lubricant during the off-season.

## PLLW-II Auto Tensioning System

The auto-tensioning system in the PLLW-II will maintain proper tension as the chain wears and stretches. A new chain will be set to the top of the tension slot. As the chain wears/stretches, the tension roller will move down the slot. When the chain tensioner is bottomed out, links must be removed to shorten the chain to its original length.

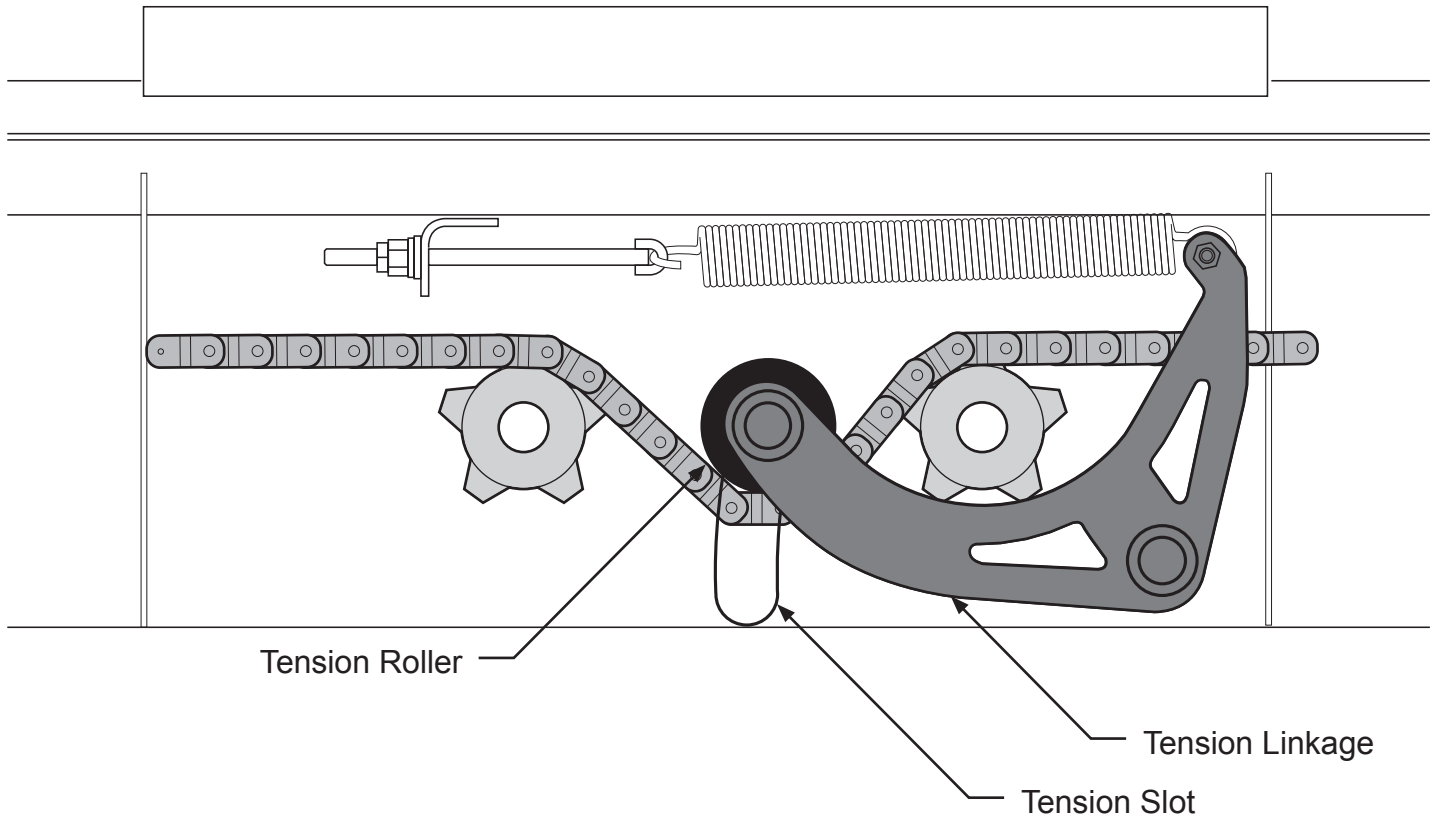



## Chain Maintenance and Service

Proper chain tension is essential for efficient operation as well as a long service life. Improper tensioning will result in excessive and rapid wear.

### Regular Maintenance

Because a conveyor chain is a wearing part, the service life can be extended of your PLLW-II chain system by following these regular maintenance procedures:

- Never leave salt or corrosive materials in the body during the off-season.
- Lubricate chain with an anti-corrosive lubricant during the off-season.
- Visually inspect the tensioning rollers every year to ensure they are intact and aligned, allowing the chain to roll smoothly.
- Grease pillow bearings using remote grease ports located at front driver side of dump body.
- Check sprocket teeth for excessive wear annually.



Good

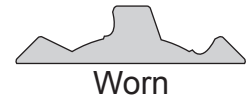

Worn

Replace Sprocket

### Adjustment

When the roller is at the bottom of the tension slot, it will be necessary to remove some links in the chain, in order to restore the chain to its original length.

To set spring to factory tension, tighten draw rod until a gap of 2" (two inches) remains between draw flange and the eyehole that holds the spring.

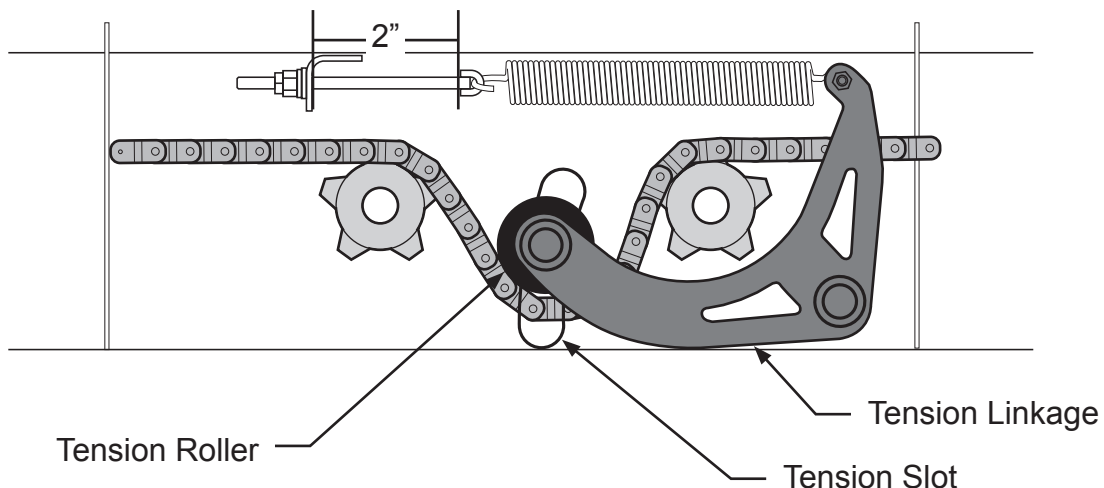

## To Remove Chain Links

1. Using a pry bar, lift the tensioning linkage high enough to release tension and place a wood block under the tensioning arm to hold the tension roller in its highest position.

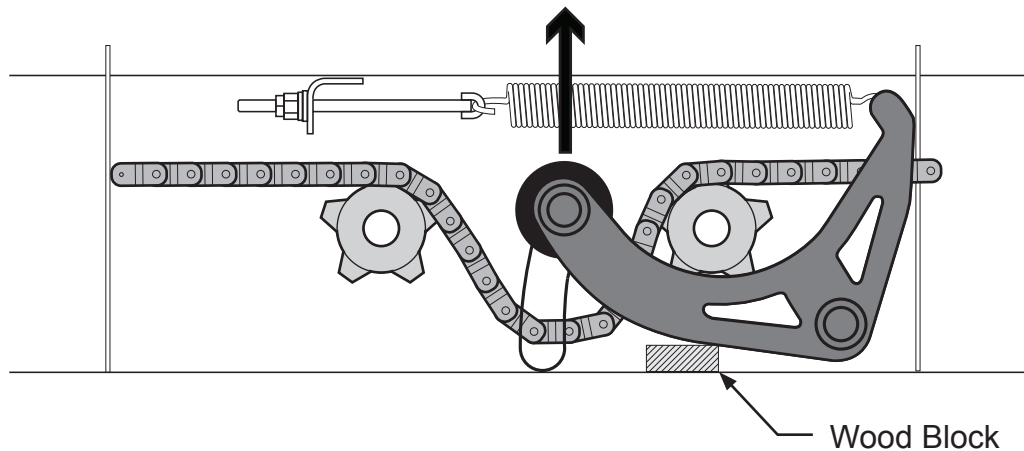

2. Run the conveyor until the the master link is at the back of the dump body (underneath the conveyor guard).

**NOTE:** The master pins are the only pins that are held in place by cotter pins. All other pins have formed collars on both ends.



3. At the rear of the body, remove the conveyor guard to gain access to the chain links.

4. Remove the cotter pins, and chain link pins to break the chain. To remove additional links, the formed collar must be ground down and the pin punched out.

5. Once the desired links are removed, replace all chain link pins and cotter pins to complete the chain.

6. Using a pry bar, lift the tensioning linkage and remove the supporting block. and gently lower, slowly easing the chain into tension. Reinstall all guards before testing.

**NOTE:** Chains are a wearing part. The recommended service life of them is 3 years. If the chain is continually stretched and shortened, it will eventually break, and potentially cause damage to other components on the equipment.



### Hydraulic fluid Specifications

The following is a list of recommended filter units and lubricants approved for use by Viking-Cives Group.

**NOTE:** Viking-Cives recommends that all hydraulic filter elements are a minimum 10-micron absolute.

Additionally the use of electronic spreader control systems requires greater filtration and therefore should be equipped with an in-line high-pressure filter and element. Viking-Cives Group recommends changing filter elements more frequently at three (3) month intervals.

VCL Item Number	Description
0560010	Inline High Pressure Filter Element 10 Micron – STAUFF
0560004	Inline High Pressure Filter Element 10 Micron – PARKER
0560031	Inline High Pressure Filter Element 10 Micron – MP FILTRI
0560009	Return Manifold Filter Element 10 Micron

Location	Fluid Type	Required Capacity
Planetary Gearbox	SAE 80/90EP Gear oil (antifoaming)	1 Liter (2 1/4 pints US).
Hydraulic System	Petro-Canada HVI 36	Varies Per Truck System*

\*Hydraulic fluid capacity can vary by the number and type of accessories on the equipment. To ensure that proper fluid levels are maintained, regularly check the oil level indicator located on the rear tower oil tank.



This Page Left Blank



LUBRICATION POINTS PLLW-II

BODY ASSEMBLY PLLW-II

ITEM ID	LOCATION	ASSEMBLY DESCRIPTION	QTY/UNIT
1	UPPER CYLINDER MTG	1/8 NPT	1
2	LOWER CYLINDER MTG	1/8 NPT	1
3	FRONT & REAR DRIVE SHAFT BEARINGS	GREASE FITTING / BEARING	4
4	DUMP HINGE BLOCK	1/8 NPT	2
5	TAIL GATE HINGE	1/4 – 28 UNF	2
6	FRONT DOOR JACK	GREASE FITTING / JACK	1
7	TENSIONER SHAFT BEARINGS	GREASE FITTING / BEARING	4





BOX 1120, NORPARK DRIVE, MOUNT FOREST, ONT. N0G 2L0 (519)323-4433 PH (519)323-4608 FX

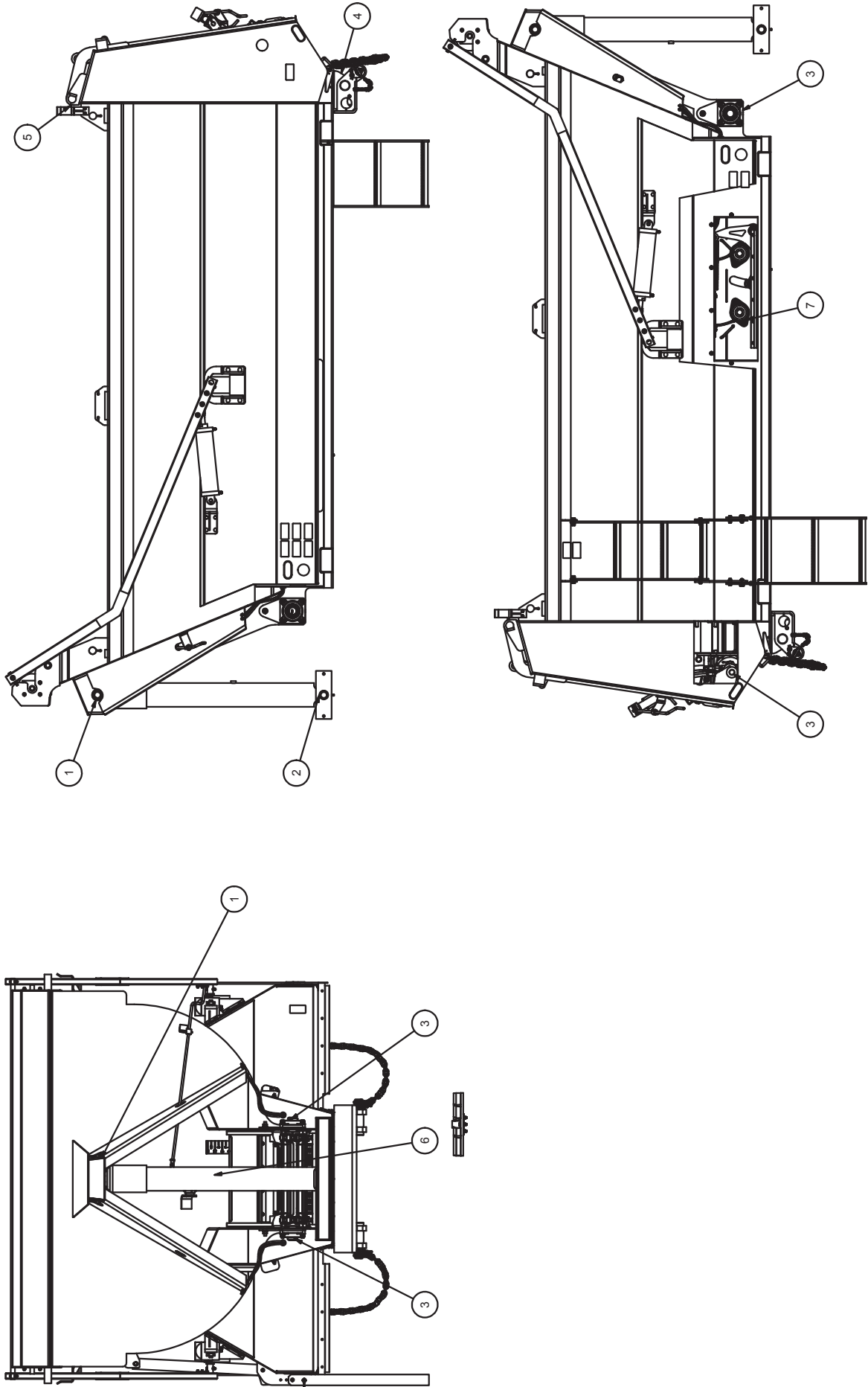

EQUIPMENT MAY NOT BE EXACTLY AS SHOWN. SOME COMPONENTS MAY BE OPTIONAL.  
TO MAINTAIN OUR ON-GOING PRODUCT AND DEVELOPMENT IMPROVEMENT PROGRAM, VIKING-GIVES LTD. RESERVES THE RIGHT TO CHANGE EQUIPMENT & SPECIFICATION WITHOUT NOTICE.



---

# Operating Instructions



**CAUTION:** Before operating any equipment, be sure to read and fully understand all caution and safety warnings. Familiarize yourself and others with all caution/warning labels and their locations. Make sure all labels are complete and legible. Replace any labels that have become unreadable and/or missing. Replacement labels can be purchased directly from Viking-Cives Group, and/or nearest authorized dealer.

**IMPORTANT:** Before putting any equipment into use, check for any worn, damaged or loose components, if necessary repair or replace. Listen for any unusual sounds, if necessary repair and/or replace worn or damaged parts.

## Cold Weather Operation

All equipment is designed to operate with hydraulic oil minimally warm. During cold weather conditions, it is recommended that the truck be run at idle with the pump engaged and circulating the oil through the system before operating equipment.

## Dump Body Operation

All operators should familiarize themselves with all equipment prior to operation. The in cab controls are placed at a comfortable reach of the operator and are clearly marked as to the equipment/function they control.

1. With the engine running, pull the dump raise lever in the cab back toward the rear of the unit.
2. If dumping a load, the air operated tailgate release valve should be pulled to the open position to operate tailgate release mechanism. This must be done before raising the body.
3. To lower body, push the dump lever forward.
4. To stop and hold dump body in any position while raising or lowering the unit, release the lever and it will automatically center itself in a neutral position.

## Sander Operation (Automated Spreader System)

An automated or electronic spreader control system enables the operator to discharge the payload manually, or have it done by the unit automatically. The system synchronizes the application rate, based on predetermined values, with the vehicle ground speed. A control console within the cab allows the operator to control any of the units spreading functions.

**NOTE:** For detailed operating instructions refer to the Manufacturers Operator's Manual that is supplied in the appendix of this manual.

## Sander Operation (Manual Spreader System)

1. The sander valve is located to the right of the driver's seat. To operate the conveyor chain and spinner, raise the lever with the round black knob to the on position. Both spinner and conveyor will begin to move. The two knobs on top of the valve block control the speed of the conveyor and spinner.  
**Warning:** Do not use flow knobs to shut off hydraulic flow, this would cause oil to blow past the relief valve and causing excessive heat.
2. To stop sander operation, push the lever with black knob down.
3. One method of controlling the discharge rate is with the control gate. Each unit is equipped with a manually operated gate that is operated by hand crank.

## Spinner Chute Adjustment

The spinner chute can be adjusted to locate sand in any location on the spinner. A salt chute is also provided for locating a salt ribbon.

By lengthening or shortening the adjustment chain on the spinner chute, the chute can dump material on either the inside or the outside of the spinner disc.

**A. Outer Disc:** Material placed nearer to the **outer edge of the disc**, will discharge towards the underside of the truck in either a forward or rearward direction (depending on the rotation direction of the disc).

**B. Inner Disc:** Material placed **nearer to the centre spindle** of the disc will discharge evenly around the circumference of the disc.

**NOTE:** Material discharge is dependant on application rates as well as the rotational speed of the spinner disc. The above information is meant to aid in calibration, and will vary accordingly.

## Disc Height Adjustment

Spinner height can be adjusted from 9"-12" from the ground by by raising the height on the spinner adjustment plates. Remove the four (4) bolts that secure it and move to the desired setting. Ensure that all bolts are firmly secured to ensure the proper operation of the spreader system.

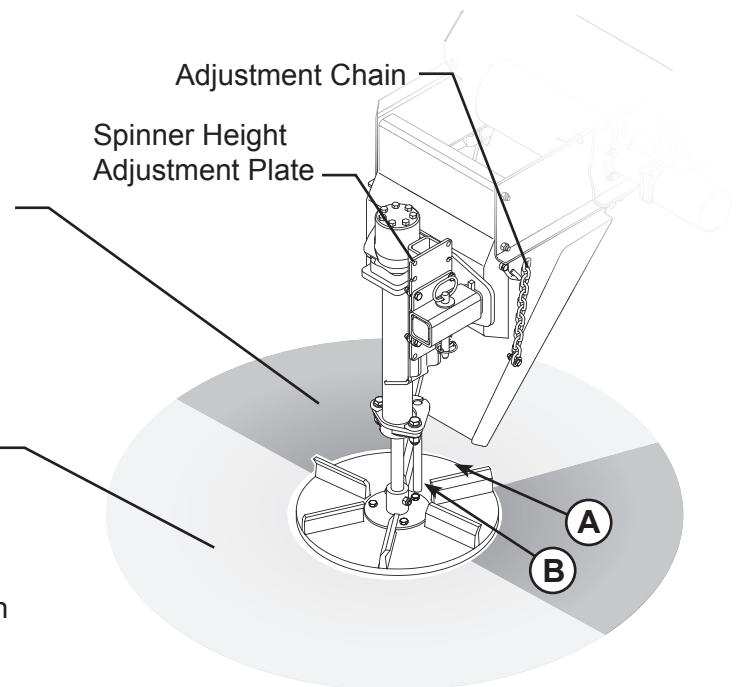



---

# Installation Sequence & Guidelines

---

The following guide is meant to guide installers and bodybuilders through the installation of the Proline Light-weight-II combination spreader. As there are numerous mounting possibilities due to differences in vehicle construction and equipment combinations, these instructions have been written as a generic overview of the installation sequence.

**NOTE:** For installations on chassis with CA (CT) dimensions other than specified, or for combination equipment installations, contact your Viking-Cives dealer or sales representative for more specific details.

1. Layout chassis frame rails, following layout drawings supplied, for frame cut off location and for identifying any chassis components such as air tanks and/or battery boxes, which may have to be moved for spinner clearance.
2. Cut off excessive frame if required and cut in body dump hinge. Install pintle plate (if applicable) at this point.
3. **NOTE:** the thickness of sub frame or hardwood can vary per installation; this will affect the cut in height of the hinge. Install pintle plate (if applicable) at this point.
4. Hydraulics Installation: install chassis mounted hydraulic components (i.e. hydraulic pump/PTO, main valve bank, etc). Install hoist base cradle, cross conveyor/spinner assembly and hydraulic components. Viking-Cives spreaders are shipped with the hydraulic circuit partially assembled. The controls and plumbing from the cab, control valve(s) and oil reservoir to the spreader, must be connected by the installers.
5. Various hydraulic arrangements/options are available and close attention must be given when installing and routing the lines of the hydraulic system:
  - Ensure that the correct drawings for the specific application are used.
  - When running control cables and/or hydraulic hoses, care must be taken not to run these items too close to moving parts and/or hot engine parts.
  - Do not kink or severely bend cable or hoses.
  - At any point where items cross any surfaces where abrasion could occur, protect cable or hose with armor.
  - Whenever possible, secure the cables and/or hoses, with ties, to the chassis frame.
6. Install hoist base cradle, cross conveyor/spinner assembly and hydraulic components.
7. Install chassis electrical wiring and rear chassis mounted lights per wiring schematic.
  - **IMPORTANT:** Ensure that wiring is not bundled or routed near hydraulic hoses.
  - Ensure that all connectors have dielectric grease applied.
8. Place spreader body on chassis frame, bolt and weld per detail drawing(s) for mounting of combination spreader and conveyor.
9. Install and connect main conveyor and dump hoist hydraulics per schematics. The hydraulic system, including the main conveyor drive components, of the Viking-Cives combination spreader has been designed to operate on 2000-PSI pressure for the body lift hoist and 1800-PSI pressure for the spreader system. There are two relief valves within the hydraulic system; the first is part of the main valve bank and is set at 2000-PSI pressure. The second is incorporated in the dual flow regulator, installed in the cab, which controls the conveyor/spinner circuit(s), and is set at 1800-PSI pressure. Installation and operation of the



hydraulic system at pressures higher than those stated above can result in premature and severe failure(s).

10. Install and connect air operated cab control(s), tailgate and tarp pneumatics per installation schematics.
11. Install box guides and mud flap brackets.
12. Run and test spreader only after reading operating/safety procedures.
13. Install or complete required spreader options such as additional lighting, conveyor covers, material screens, etc.
14. Prep for finish prime and paint.
15. Complete final test and inspection.
  - Check the fluid level in the hydraulic oil reservoir. If the sight indicates low oil level, add the appropriate amount of the specified hydraulic fluid.
  - Check hydraulic system pressures: Dump hoist operation 2000-PSI, spreading operation 1800-PSI.
  - Check all components for loose and/or missing fasteners, if required tighten and/or replace.
  - Visually inspect all hydraulic connections and hoses for leaks.
  - Visually inspect all caution and warning decals, replace decals if missing. All decals should be complete and legible.

# Dumping Operation



**DANGER:** Dumping operations can be extremely dangerous. Always ensure that you follow the proper safety precautions and exercise common sense when dumping loads. Failure to do so may result in damage to the equipment, severe injury, or death.



**DANGER: DO NOT dump on uneven, unstable ground.**



**WARNING: Prior to dumping, ensure that the tailgate claws have been released.**

**ALWAYS** ensure that the vehicle is parked on a stable and level surface.

**NEVER** attempt to raise dump body if the surface grade exceeds 6 degrees. Raising a load on an uneven surface can cause the vehicle to tip.

**NEVER** attempt to raise a load on excessively muddy or moist surfaces.

**NEVER** transport the vehicle with a disproportionately rearward load. Uneven loads that collect at the tailgate can alter the vehicle's weight distribution and affect the handling and stability of the vehicle when in motion.



**DANGER: Always stay clear of overhead structures and power lines.**

**ALWAYS** ensure that there are no power lines or overhead structures that can interfere with the dump body while it is being raised.

**NEVER** raise dump body under power lines. Fallen power lines can cause severe injury or death to operators and bystanders, and can leave large areas without power for long periods of time.

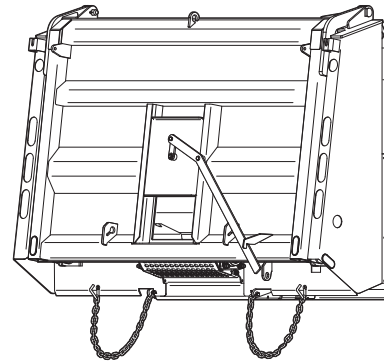

**NEVER** attempt to dump through the coal door by raising the dump body as it can cause the load to shift to the rear of the truck. It is only to be used to discharge material out the rear when the body is down using the conveyor.



**WARNING: Clear all bystanders to a safe distance when dumping**

**ALWAYS** ensure that the area is clear of bystanders. Clear discharge area (rear and the sides of the vehicle) of all bystanders.

**ALWAYS** ensure that all bystanders are visible to the operator while dumping.

**IT IS THE OPERATOR'S RESPONSIBILITY** to make note of and be aware of all bystanders.

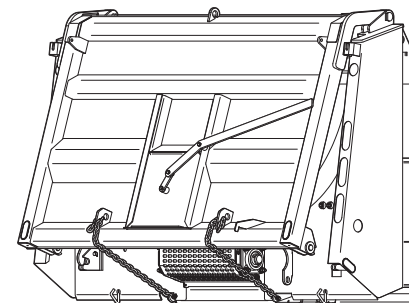

If you are planning to use the spreader chains, fasten them to the appropriate length using the chains and mounting brackets. Set the chains at an equal length.

---

# Tailgate Removal



**DANGER:** Always observe and follow safe work procedures when lifting heavy objects. Ensure that all bystanders are at a safe distance, and that all necessary lock out and safety precautions are followed.

1. Park the vehicle on a stable and level surface, engage the parking brake, chock the wheels and lock out the machine.
2. Place a strap, chain or cable through the center lifting eye.



**WARNING:** Ensure that all rigging and lifting implements (crane, hoist, etc...) are appropriately rated to hold the load, as some rear tailgates can weigh up to 800 lbs. (363 kg).

3. Slowly raise the rigging until the cable is taught, and the weight of the tailgate is off the hinges.
4. Remove the tailgate upper pins.
5. Open the lower tailgate hardware by using the tailgate release mechanism (located in-cab)
6. Slowly move the tailgate in an Upward & Rearward direction. Ensure that the upper and lower hinges do not bind or catch.



**WARNING:** Keep all body parts away from suspended load. **DO NOT** attempt to release an impeded tailgate with bare hands.

7. Lay the tailgate horizontally in a safe area to ensure it does not fall during storage.
8. To replace the tailgate, repeat the above steps in reverse order.

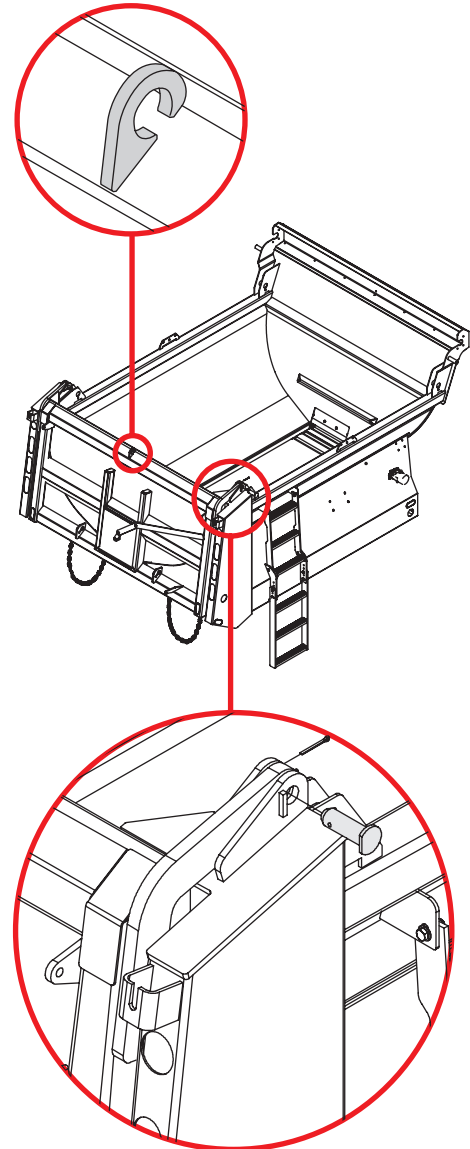

**NOTE:** Some tailgate hinges will have washers between the hinge plates. Return all washers when re-installing the tailgate. Replace any worn or damaged hinge hardware before replacing the tailgate.





This Page Left Blank



# COMMON PRO-LINE PLLW-II COMPONENTS

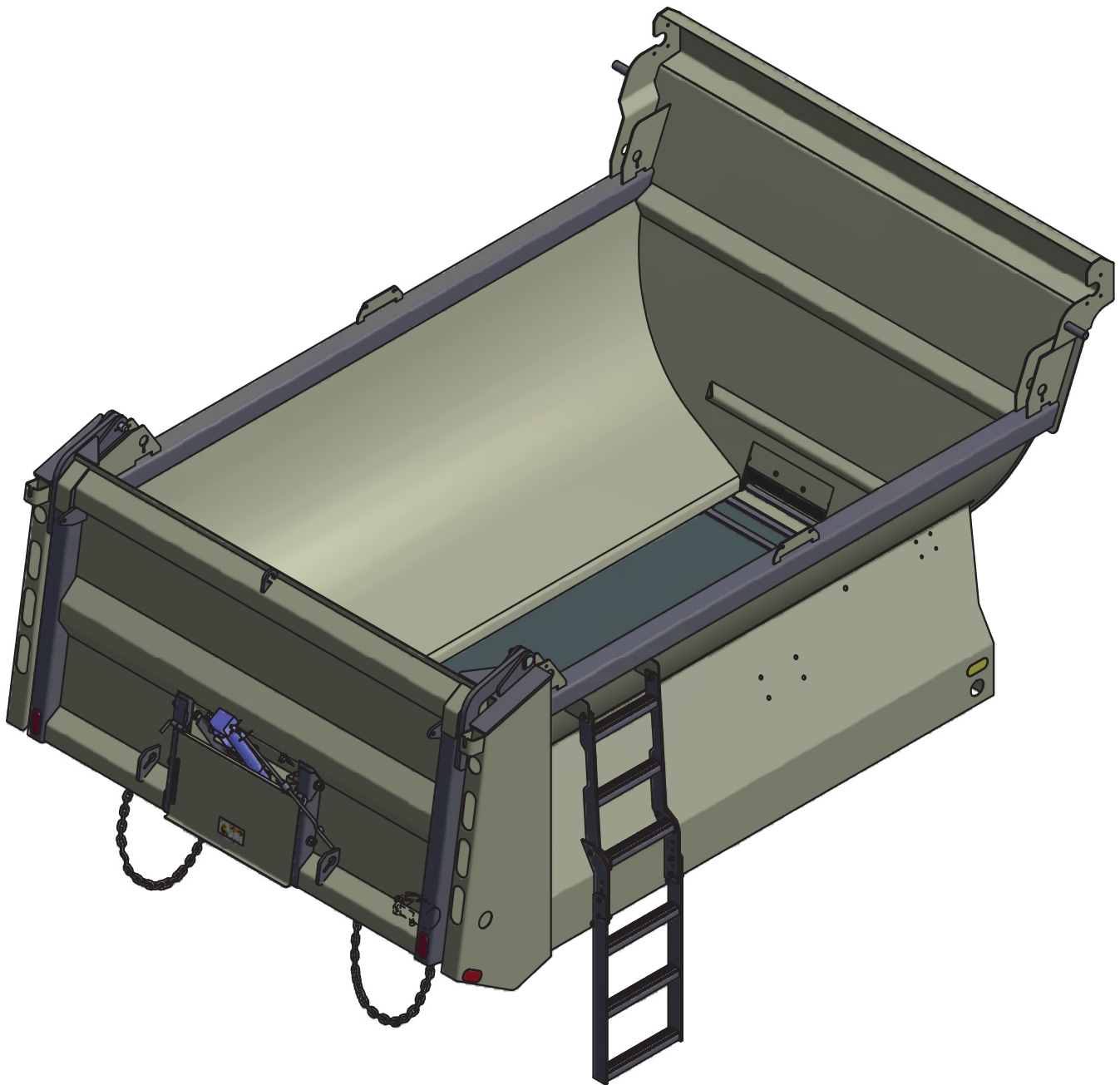

EQUIPMENT MAY NOT BE EXACTLY AS SHOWN. SOME COMPONENTS MAY BE OPTIONAL.  
TO MAINTAIN OUR ON-GOING PRODUCT DEVELOPMENT AND IMPROVEMENT PROGRAM, VIKING-CIVES LTD. RESERVES THE RIGHT TO CHANGE EQUIPMENT & SPECIFICATION WITHOUT NOTICE.



## 0530714: AIR TAILGATE CONTROL SYSTEM

ITEM ID	ITEM NO	DESCRIPTION	QTY REQ
1	0630372	FITTING BRASS 3/8 MNPT X 3/8 AIR 90	2
2	1485-6-15	3/8 DOT TUBING 15 FT	1
3	PV-689-BRACK	POWER VALVE ASSEMBLY C/W BRACKET	1
4	QE3-QEA	HIGH SPEED EXHAUST ASSEMBLY	2

### NOTES

ITEM 1485-6-15 IS NOT SHOWN

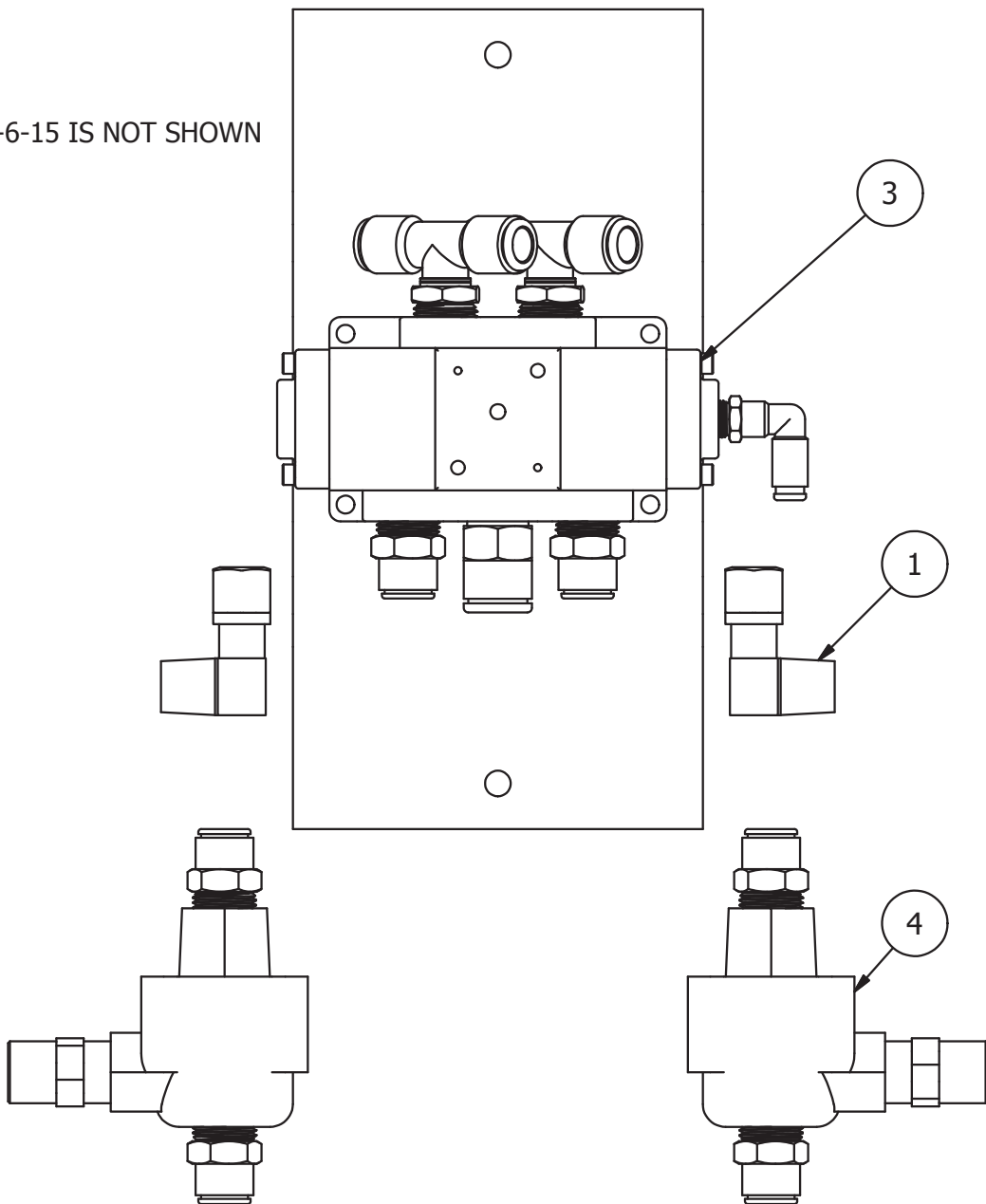

EQUIPMENT MAY NOT BE EXACTLY AS SHOWN. SOME COMPONENTS MAY BE OPTIONAL.  
 TO MAINTAIN OUR ON-GOING PRODUCT DEVELOPMENT AND IMPROVEMENT PROGRAM, VIKING-CIVES LTD. RESERVES THE RIGHT TO CHANGE EQUIPMENT & SPECIFICATION WITHOUT NOTICE.



BOX 1120, NORPARK DRIVE, MOUNT FOREST, ONT. N0G 2L0 (519)323-4433 PH (519)323-4608 FX

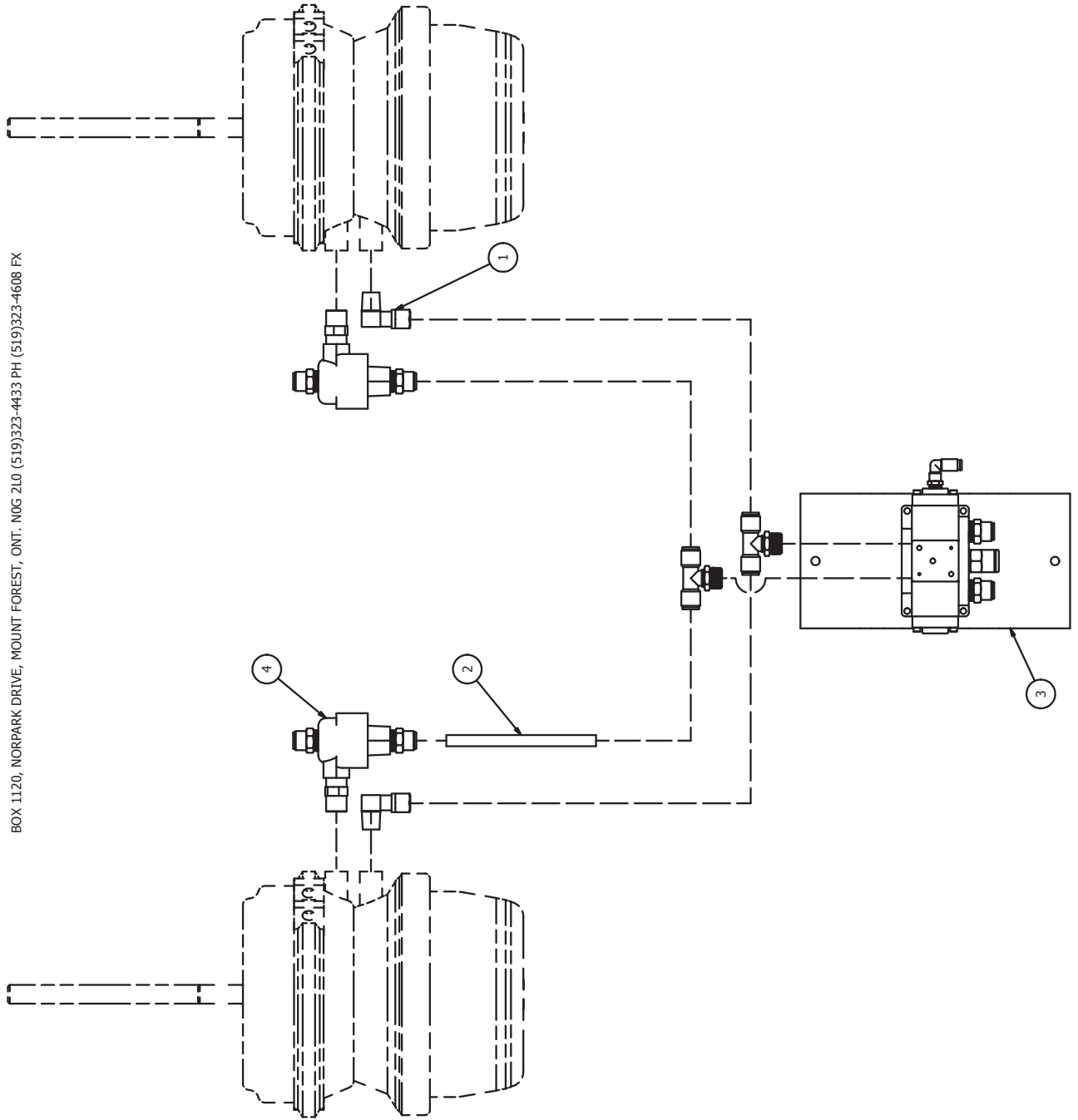

EQUIPMENT MAY NOT BE EXACTLY AS SHOWN. SOME COMPONENTS MAY BE OPTIONAL.  
TO MAINTAIN OUR ON-GOING PRODUCT DEVELOPMENT AND IMPROVEMENT PROGRAM, VIKING-GIVES LTD. RESERVES THE RIGHT TO CHANGE EQUIPMENT & SPECIFICATION WITHOUT NOTICE.



01303477: FLANGE COUPLER ASSEMBLY 2.000 - 2.000

ITEM ID	ITEM NO	DESCRIPTION	QTY REQ
1	01303474	FLANGE COUPLER 2.000 ID MALE	1
2	01303475	INSERT 0.625 - 0.385 FLANGE COUPLER PL	6
3	01303476	FLANGE COUPLER 2.000 ID FEMALE	1
4	HW14A-06	FLATWASHER SAE 3/8 ZINC	6
5	HW30E-06	NUT CENTER LOCK 3/8 UNC ZINC	3
6	HW42A-0612	BOLT HEX 3/8 X 1 1/2 UNC ZINC GRADE 2	3
7	HW70M-0508	SCREW SET HS 5/16 X 1/2 KNURL PT	4

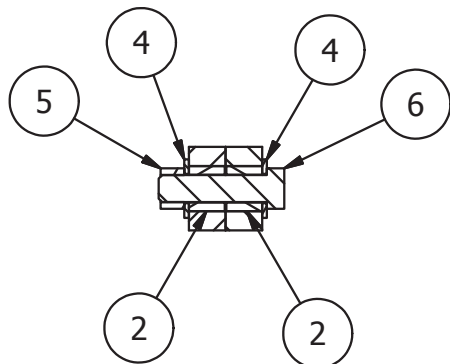

SECTION E-E

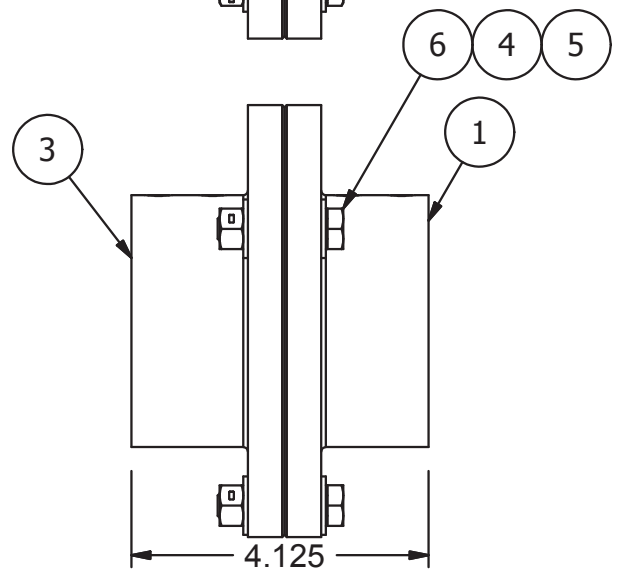
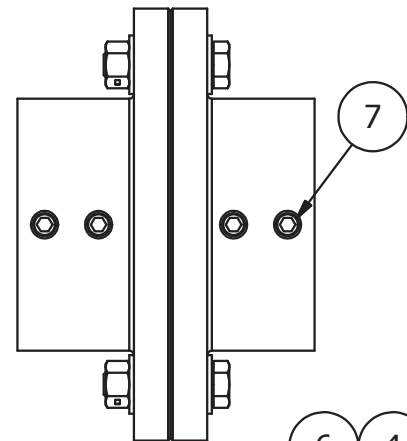
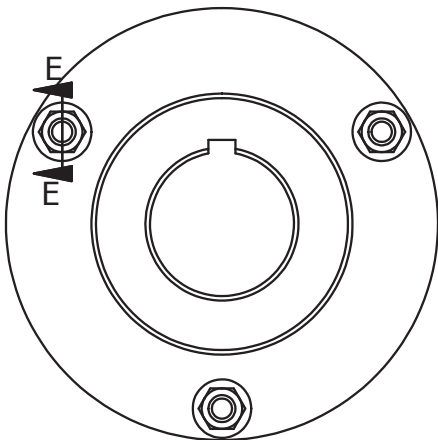

**IMPORTANT:** ALWAYS use specified Grade 2 hardware for the shear coupler bolts, when replacing broken or lost bolts. The use of improper hardware can cause damage to the gear box and spreader body if the belt becomes jammed.

EQUIPMENT MAY NOT BE EXACTLY AS SHOWN. SOME COMPONENTS MAY BE OPTIONAL.  
 TO MAINTAIN OUR ON-GOING PRODUCT DEVELOPMENT AND IMPROVEMENT PROGRAM, VIKING-CIVES LTD. RESERVES THE RIGHT TO CHANGE EQUIPMENT & SPECIFICATION WITHOUT NOTICE.